



The high-efficiency boiler of Mark

The Mark MEGAFLEX is a very compact and sustainable high-efficiency boiler for industrial use. Available in capacities of 850 kW and 1020 kW.

The MEGAFLEX is suitable to heat offices, garages, warehouses, apartment buildings, workshops, distribution centers and showrooms.

For a complete heating solution from Mark it is also possible to combine the MEGAFLEX boiler with water-supplied products such as the TANNER MDA and INFRA AQUA ECO.

Benefits

- Competitive pricing
- Proven and innovative technology
- Cast aluminum heat exchanger
- Robust
- Low-noise
- Advanced diagnostic system
- Very low maintenance interval
- Low service interval
- Integrated pump control
- Closed version available
- Cascade control already integrated
- Weather-dependant control
- Control:
 - On/off thermostat
 - OpenTherm
 - BMS 0-10V control

Dimensions

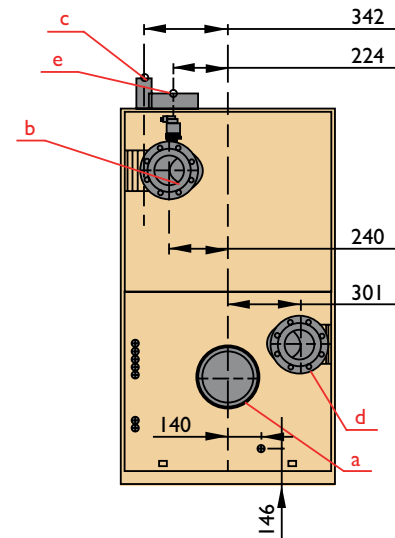
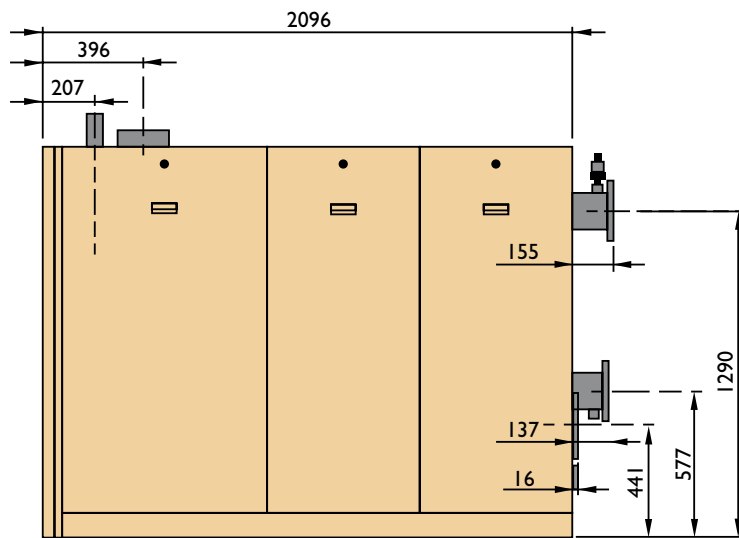
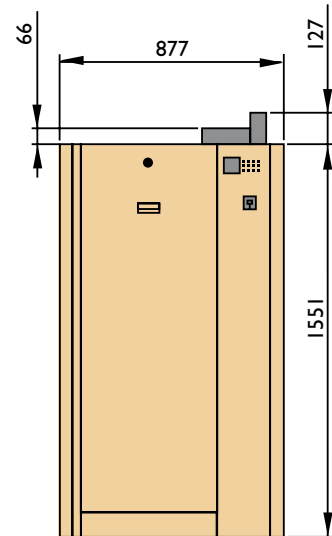
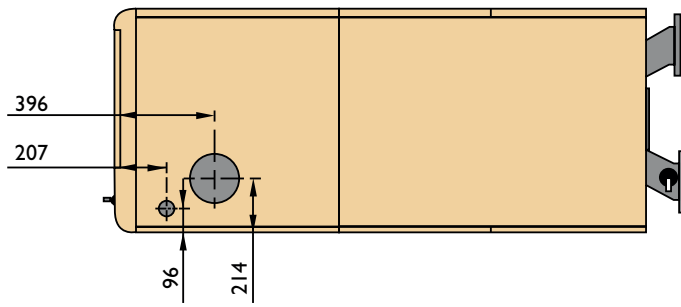

- a = Flue gas \varnothing 250mm
- b = Supply DNI25 PN6
- c = Gas connection R2,0"
- d = Return DNI25 PN6
- e = Combustion air inlet \varnothing 200mm

Technical information

MEGAFLEX		HR 850	HR 1020
Nominal input	kW	850	1020
Efficiency	%	107	107
Operating pressure	bar	6	6
Weight	kg	348,4	412,6
Supply voltage		400V~3N/10	

