

INFRA HE

High performance black radiant tube heater

Gas-fired high performance black radiant tube heater with premix burner and electric ignition. Powers of 35 and 50 kW.



For more information, downloads and videos, visit the Infra HE page on our website



Black tube radiant heater with a low emission

The Mark INFRA HE gas-fired radiant heaters have been developed for the highest possible efficiency in combination with low NOx emissions (< 35 mg/kWh). This makes the units very suitable for BREEAM projects!

Mark INFRA HE black tube radiant heaters heat with long-wave infrared radiation. Radiant heating is based on the principle of heat transfer from a warm object to an object of lower temperature by means of electromagnetic wave energy. This electromagnetic wave, not hindered by air, radiates walls, floor and the people present in the room.

As soon as the infrared radiation gets in contact with the human body, it is converted into heat. This does not cause any change in the air temperature. This method of heat generation is considered very pleasant.

The more intense the radiant heat is, the less the actual air temperature has to be increased for a comfortable indoor climate. Therefore, heating with the Mark INFRA system is much more economical compared to conventional systems.

Possible applications include: sports halls, production facilities, aircraft hangars, showrooms and garages.

Benefits of the Infra HE black tube radiant heater are:

- No spreading of dust and low noise level during operation
- Can be used in a focused way to enable a high energy efficiency
- A flue efficiency higher than 90%
- A uniform heat distribution across the entire length of the radiator is achieved by the use of an overpressure burner with a long stable flame, in combination with built-in turbulators in the radiant tube
- Premix burner technology for optimal combustion and very low NOx emissions.

Product features

- Modulating control that optimally adapts the input capacity to the heat requirement
- Available in 2 different capacities of 35 and 50 kW
- Sizes of 9 and 12 meter in length
- A NOx emission of < 35 mg/kWh
- Highly reflective reflector hood, double air insulated
- Can be optimized energetically by using a flue gas cooler
- The highly reflective radiation hood features integrated V-shaped reflectors and end caps
- Easy installation and maintenance
- Suitable for natural gas with 20% hydrogen gas (H2) admixture



Remote connection possible with the PinTherm Infra HE Connect!

Dimensions

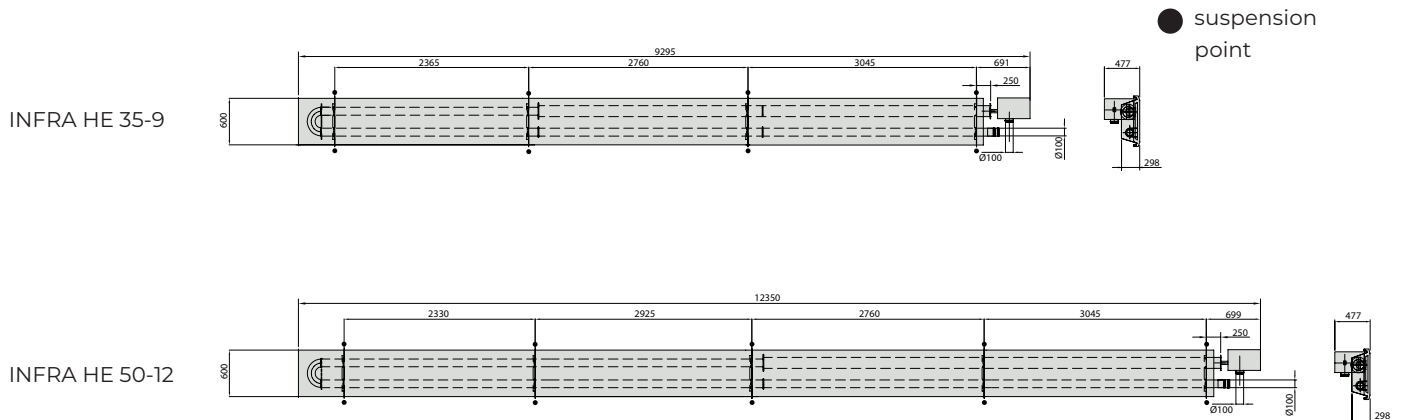

Technical information

Type		35-9	50-12
Nominal load (NCV)	kW	35,0	50,0
Flue efficiency (NCV)*	%	90,4 - 94,1	90,0 - 93,5
Flue efficiency (NCV)**	%	96,3 - 94,8	94,3 - 95,7
Gas consumption G25 (15 °C)	m ³ /h	4,14 - 2,07	5,98 - 2,98
Gas consumption G20 (15 °C)	m ³ /h	3,66 - 1,83	5,23 - 2,63
Gas consumption G31 (15 °C)	kg/h	2,72 - 1,36	3,88 - 1,94
Gas consumption G30 (15 °C)	kg/h	2,76 - 1,38	3,94 - 1,97
NOx-emission (GCV)	mg/kWh	34,8* / 32,9**	24,5* / 23,3**
Weight	kg	245	322
Electrical power	W	81-30	113-36
Recommended suspension height, horizontal	m	5,5	6,8
Recommended suspension height, 30° angle	m	5,0	6,3
Sound level at 5 metres	dB(A)	41	42

* without flue gas cooler / ** with flue gas cooler (condensation drain required)

Accessories - flue gas exhaust

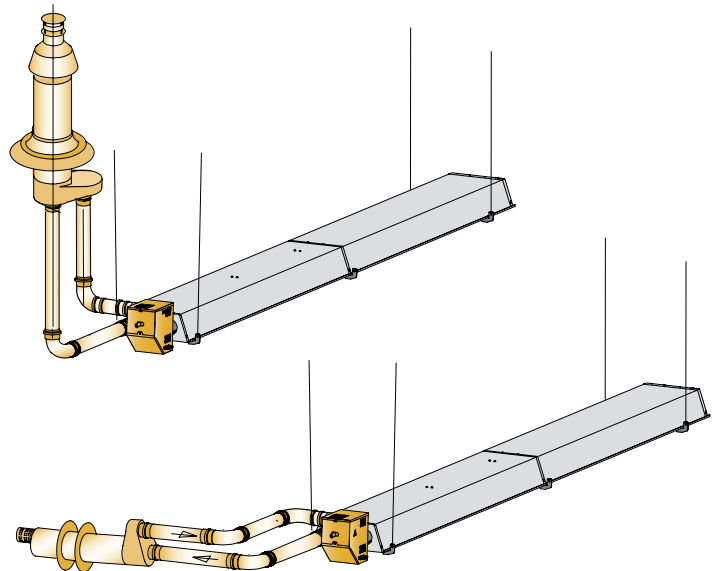
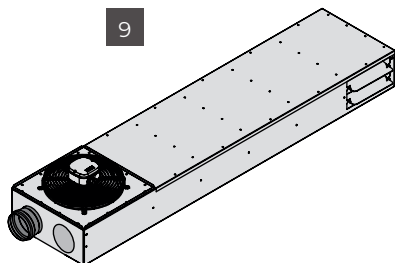
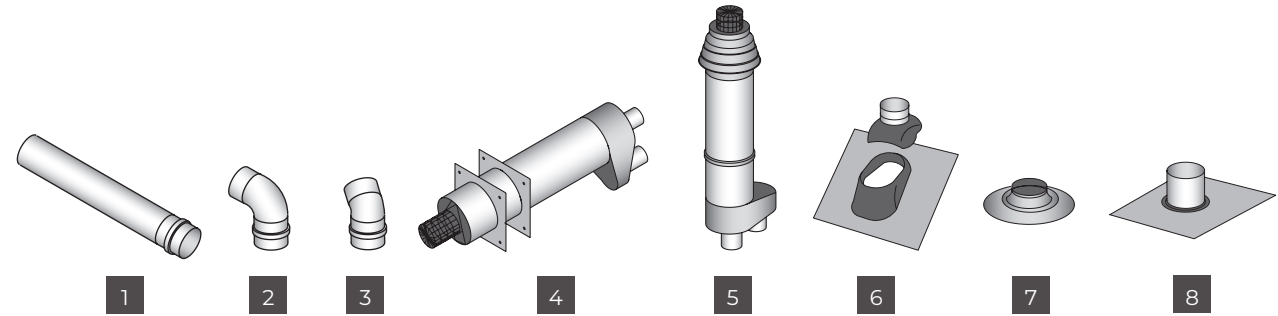

- 1 Extension set
- 2 90° elbow
- 3 45° elbow
- 4 Single flue set horizontal
- 5 Single flue set vertical
- 6 Roof flashing for pitched roof
- 7 Adhesive plate
- 8 Flexible roof flashing for cladded roof
- 9 Flue gas cooler

Controls

max. 8 units

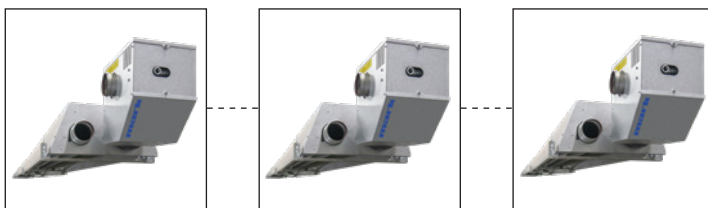

Control combination options

Infra HE + **1** + **2**

See price list for description and code numbers of the relevant items