



**mark**

building climate technology

# INFRA AQUA OPTIMA

High-Efficiency  
radiant panel

Efficient and localized heating  
with a wide range of applications

**Dedicated  
to people.**

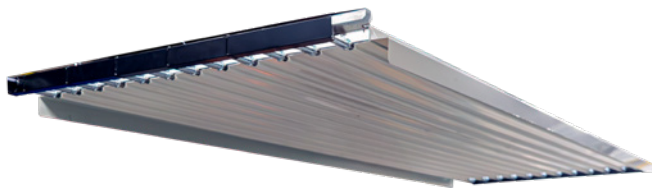

## Heating and cooling with extra high radiant efficiency

The Infra Aqua Optima is a water-fed radiant panel optimized for high radiant efficiency. Equipped with insulation to prevent heat radiating upward.

This product offers heating by radiation, thus noiseless without the displacement of air. Thus, the Infra Aqua Optima has a very wide range of applications, this applies to both utility and industrial buildings.

Due to the short heating time and direct release where the heat is needed, high energy savings can be achieved.

The panels are supplied in lengths of 4, 5 or 6 meters and can be connected in series to create longer tracks. The panels or strips can also be hung in parallel to heat and cool larger spaces.

As standard, the panel is coated in the color white RAL 9010. Other RAL colors are available on request.

### Product features

- High radiant efficiency, up to 88%.
- Easy installation.
- Low weight per meter.
- Even temperature distribution and low vertical temperature gradient.
- No air movement and therefore no dust or drafts.
- Completely maintenance-free and long service life.
- Space-saving and can be used anywhere.

### Accessoires

- Volume flow controllers
- Pressure couplings
- Adjustable suspension cable set
- PinTherm Infra Connect IoT/WiFi with black ball sensor

### Infra Aqua variants

Type	Eco	Design	Optima	Optima+
Power	+++	+	++	++
Turnover	+	+	++	+++
Ease of installation	++	+++	+++	+++



## What is radiant heating

Radiant heating is the radiating of heat from a heat source to a colder object. This is done through electromagnetic radiation, which heats surfaces directly and not the air between heat source and heated surfaces. The concept is best summarized as:

**Radiant heating feels like sunshine on a winter day: you feel the warmth immediately, without having to heat up the entire room first.**

Radiant heating is generally experienced as more pleasant than convection heating; the heating is direct and the room does not feel overwhelmingly warm.

## Application of radiant heating

Radiant heating has been used for decades in spaces ranging from 2.5 - 25 meters suspension height. These heating panels are suspended from the ceiling and therefore do not take up any space in the work environment itself. They are quickly installed, have no maintenance and have a long service life.

Radiant panels are great for zone or local heating; saving a lot of heating costs. They heat only the surfaces where heating is needed.

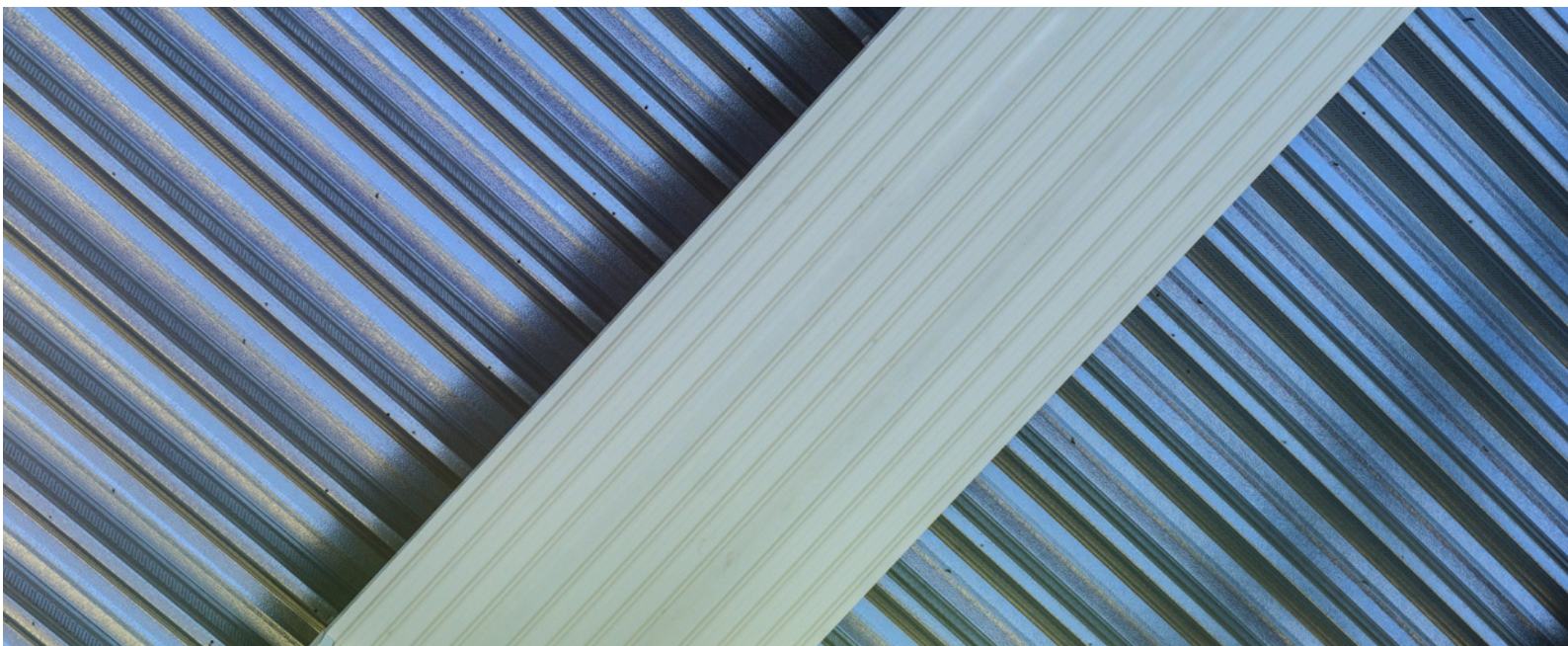

## The Optima

The Infra Aqua Optima is available in the following variants: Optima 2, Optima 3, and Optima 4. Each of these has a different width and therefore capacity. This makes them versatile, depending on the desired heating and cooling capacity for the space.

All variants are easy to install and virtually silent. Further on in this brochure, you will find information about the projection for an installation.

## The Optima+ for more radiant efficiency

The different types also have a plus variant: the Optima 2+, Optima 3+, and Optima 4+.

The Optima+ features specialized profiles and an extra layer of insulation, resulting in a peak radiation efficiency of 88% based on measurements by HLK, a significant improvement over the 70% achieved by commonly used radiant panels.

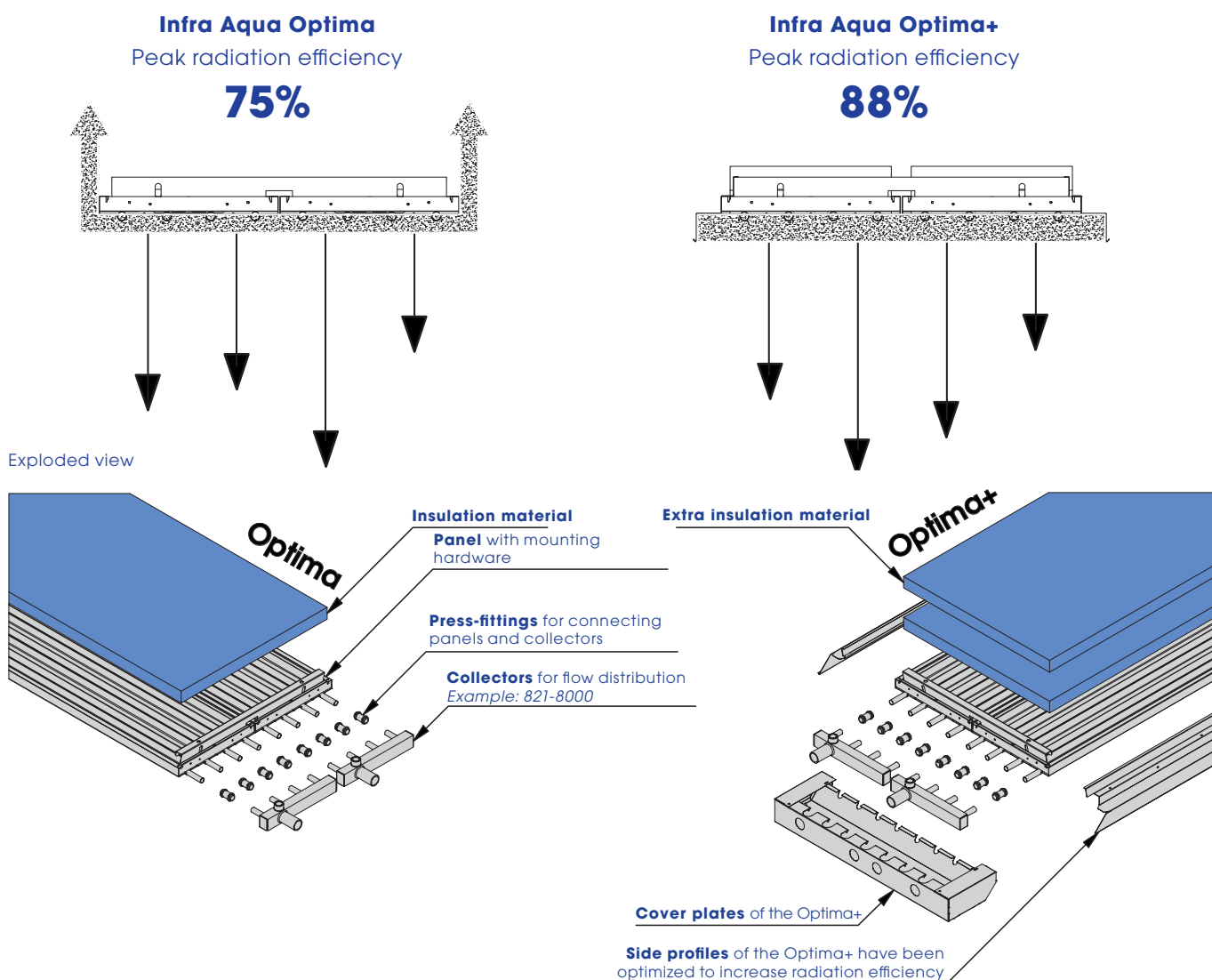

Product characteristics	Unit	Optima 2	Optima 3	Optima 4
Outer pipe diameter	mm	15	15	15
Maximum operating temperature	°C	120	120	120
Maximum operating pressure	bar	10	10	10
Operating weight of 4-meter panel, with water content and insulation	kg	31.5	47.4	63.2
Operating weight of 5-meter panel, with water content and insulation	kg	39.2	58.9	78.5
Operating weight of 6-meter panel, with water content and insulation	kg	46.8	70.3	93.8

**Space and Assembly**

The Infra Aqua Optima and Optima+ are widely applicable for their areas of use, including showrooms, hardware stores, sports halls, factories, workshops, and production halls.

Distribution across the width of the room is determined by the required power in relation to the mounting height and number of tracks. The rule of thumb is that the maximum distance between the centers of panels is 1 times the mounting height; the distance to the wall is 1/3 times the height.

**Legend**

**A** Mounting height.

**B** Width of the space.

\* Rule of thumb for minimum center-to-center distances.

Front view

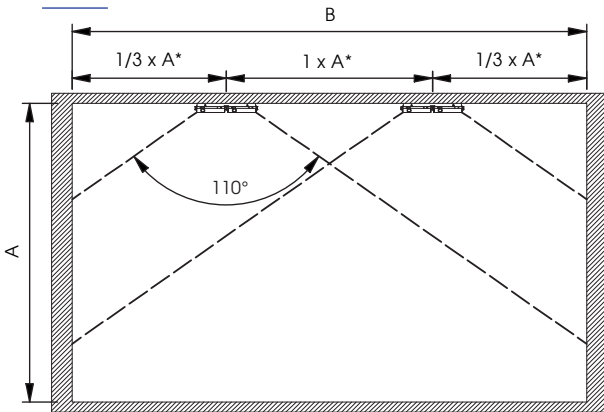

**Direct mounting to ceiling**

Example: Optima 2+.

For low spaces, it is possible to mount the Infra Aqua Optima directly to the ceiling. Mounting directly to the ceiling requires less mounting material and is ideal for low spaces.

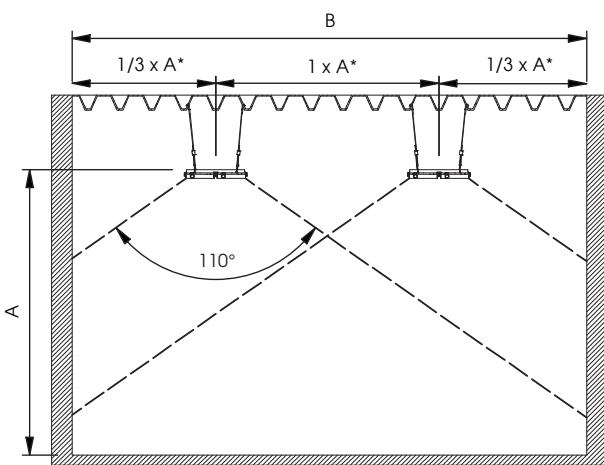

**Hanging from the ceiling**

Example: Optima 2+ to a sheet pile wall with mounting kits.

The Optima and Optima+ are versatile hanging installations that can be mounted at the desired height using optional mounting materials. Mark's mounting kits are specially designed for wide applicability and quick and easy installation.

**Mounting kits**

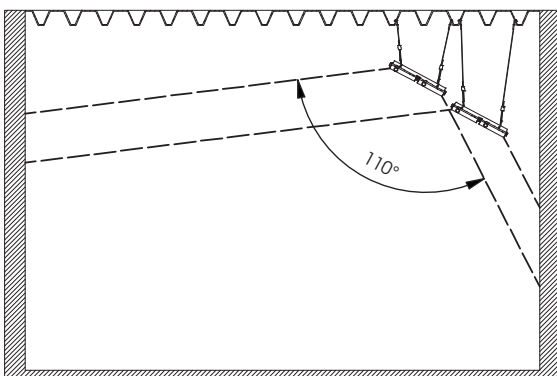
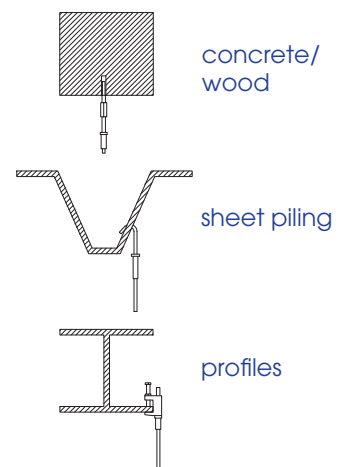

**Hanging at an angle**

Example: Optima 2+ to a sheet pile wall with suspension sets.

To reduce the obstruction of the room height, heating panels can be mounted at an angle. With this mounting method, the Optima and Optima+ have convection loss, which reduces the radiation efficiency.

It is strongly advised not to install the Optima or Optima+ in this manner. The Infra Aqua Eco focuses more on power and is more suitable for this purpose.



**Modular construction**

The Infra Aqua Optima and Infra Aqua Optima+ are available in 4, 5, and 6-meter panels for all models. Panels can be connected in series to create longer installations.

Mark uses comprehensive calculation programs and offers free, no-obligation calculations and quotes.

**Assembly**

The panels are hung every 2 meters and may therefore have a different hanging pattern depending on their length. The required parts can be calculated based on the composition of the product. The distance between hanging brackets is indicated below with an M.

**Optima 4 meter panel**

Example: single Optima 2 without covers.

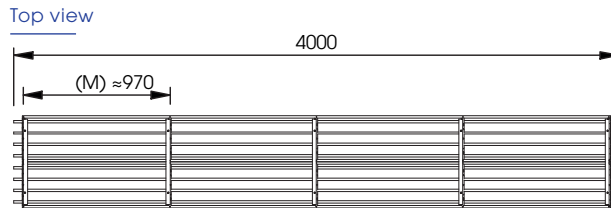

**Legend:**

**M:** Distance between mounting points on axle.

**Optima 5 meter panel**

Example: single Optima 2 without covers.

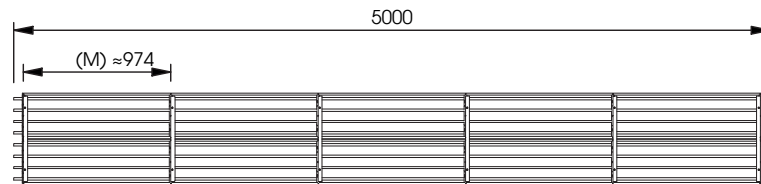

**Optima 6 meter panel**

Example: single Optima 2 without covers.

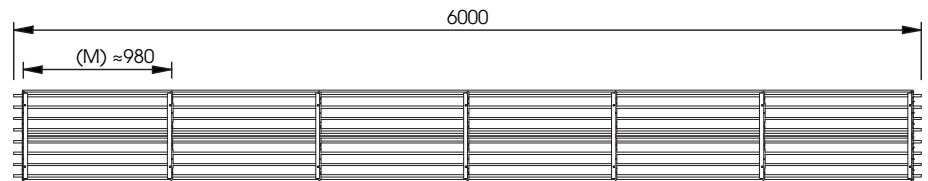

**Optima 4 meter panel**

Example: single Optima 2+ with caps, subsequent lengths are shorter.

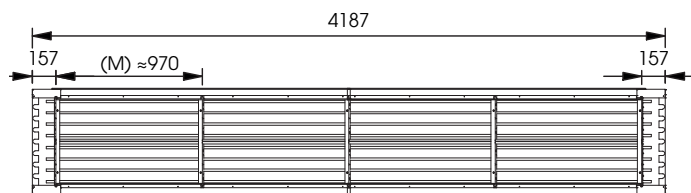

**Optima 5 meter panel**

Example: single Optima 2+ with caps, subsequent lengths are shorter.

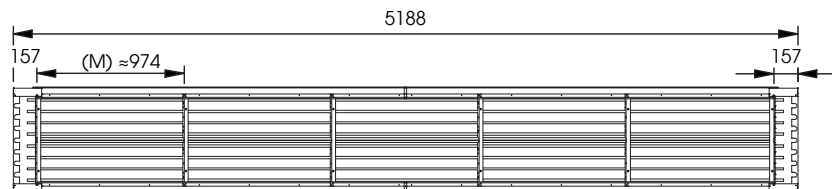

**Optima 6 meter panel**

Example: single Optima 2+ with caps, subsequent lengths are shorter.

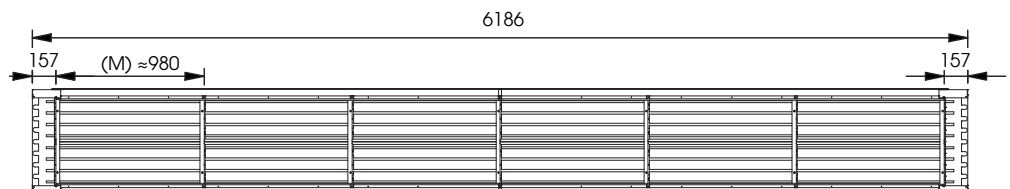

**Types**

The different types of Infra Aqua Optima and Optima+ are designed to deliver a wide range of power. A defining factor is the mounting height and thus the mounting distance between the tracks.

Depending on the projection and transmission capacity, it is possible to determine what type of product is required. For example, the Optima 4+ for high power and the Optima 2+ for lower power.

Please contact Mark for a free calculation and a no-obligation quote.

Front view of the Optima variants

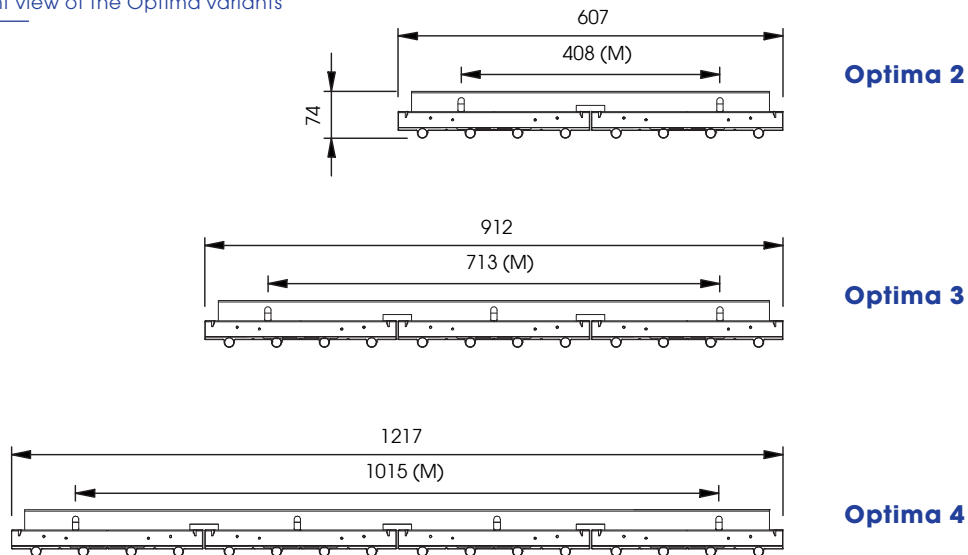

Front view of the Optima+ variants (without end caps)

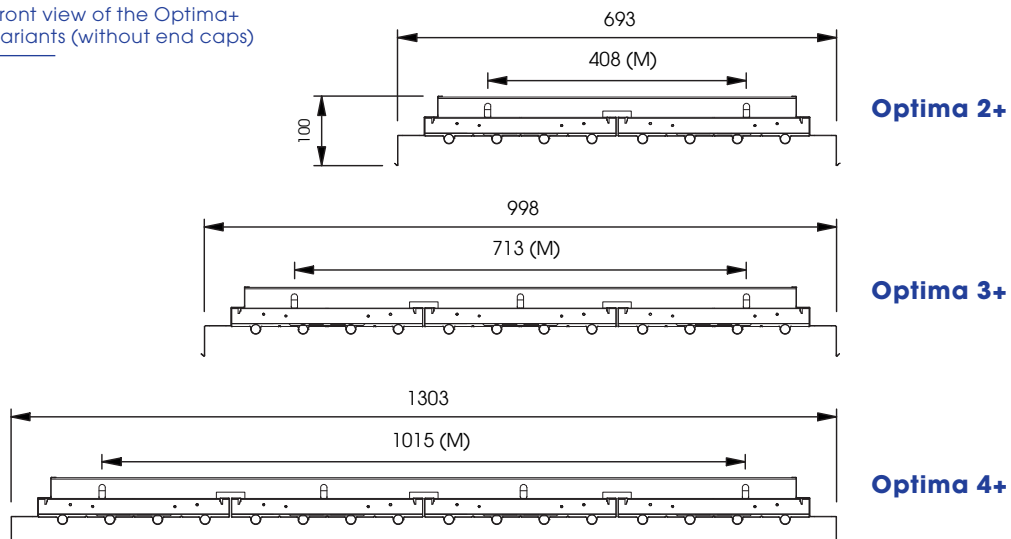

# INFRA AQUA OPTIMA

## A pleasant indoor climate

Mark Climate Technology is happy to advise you on creating a pleasant indoor climate for your project. With free advice (including on-site), our own service department, and a wide range of products, we can provide tailor-made solutions for every customer.









## Projection and design advice

The following pages describe the manual step-by-step process for creating a configuration, including the required number of lanes and the associated data.

These steps form the basis for choosing a product, but the easiest way to obtain a complete, customized calculation is to contact Mark Climate Technology for a free, no-obligation solution. Each step includes the action to be taken, the information required, and an example.

### Step 1 - Define system temperatures

Once a potential product has been selected, it determines the system temperatures that are set by the heating unit, such as a heat pump. Use this to determine the required temperatures and properties of water at the return temperature.

#### 1.1 Define the system temperature data

Name	Description	Example
$T_A$ (°C)	System supply temperature during heating.	45 °C
$T_R$ (°C)	System return temperature during heating.	40 °C
$T_O$ (°C)	Desired room temperature during heating.	16 °C

#### 1.2 Perform calculations on system temperatures

Name	Description	Calculation	Example
$\Delta T_{AR}$ (°K)	Delta supply/return during heating	$\Delta T_{AR} = T_A - T_R$	= 5 °K
$\Delta T_E$ (°K)	Overtemperature during heating	$\Delta T_E = (T_A + T_R) / 2 - T_O$	= 26.5 °K

### Step 2 - The space and capacity required

#### 2.1 Define the details of the space and layout.

Name	Description	Example
L (m)	Length of the space, in the direction of the track.	23 m
B (m)	Width of the space, perpendicular to the direction of the track.	6 m
Ho (m)	Installation height of the track.	3 m
$Q_N$ (kW)	Power required for the entire space, based on the projection of the space.	15 kW

#### 2.2 Perform the calculations for the space and layout.

Name	Description	Calculation	Example
Lo (m)	Maximum length of a single track.	$Lo = L - 3$	20 m
nB (#)	Minimum number of tracks in the space.	$nB = (B - Ho \times 2/3) / Ho$	2 lanes
$Q_{NB}$ (kW)	Power requirement per track.	$Q_{NB} = Q_N / n_B$	7.5 kW
$Q_{NM}$ (W)	Power requirement per meter of panel.	$Q_{NM} = Q_{NB} / Lo \times 1000$	375 W

### Step 3 - Determine the required product and calculate the capacities.

#### 3.1 Make a product choice based on capabilities

Description	Example
In the heat emission table, find the power per meter (QM) closest to the required power per meter (QNM) at the excess temperature (ΔT <sub>E</sub> ).	With 3 lanes, there is a possibility: Number of lanes = nB = 3 Required power per lane = QNB = 5 kW Required power per meter = QNM = 250 W/m Power per meter from table = QM = 260 W/m This is the selected example product: Optima4+.
If there are no options, the number of lanes can be increased by 1 to reduce the required power per lane.	
With a required power per meter (QNM) of 375 W at an excess temperature (ΔT <sub>E</sub> ) of 26 °C, there are no options in the heat dissipation table.	

Heat output table for the Optima and Optima+

ΔT <sub>E</sub>	Optima 2				Optima 3				Optima 4				Optima 2+				Optima 3+				Optima 4+				
	Q <sub>M</sub>	Q <sub>V</sub>	Q <sub>M</sub>	Q <sub>V</sub>	Q <sub>M</sub>	Q <sub>V</sub>	Q <sub>M</sub>	Q <sub>V</sub>	Q <sub>M</sub>	Q <sub>V</sub>	Q <sub>M</sub>	Q <sub>V</sub>	Q <sub>M</sub>	Q <sub>V</sub>	Q <sub>M</sub>	Q <sub>V</sub>	Q <sub>M</sub>	Q <sub>V</sub>	Q <sub>M</sub>	Q <sub>V</sub>	Q <sub>M</sub>	Q <sub>V</sub>	Q <sub>M</sub>	Q <sub>V</sub>	Q <sub>M</sub>
90	624	285	895	426	1185	555	597	285	847	426	1109	555	54	342	154	492	228	651	299	329	154	468	228	611	299
89	615	281	883	420	1170	548	589	281	836	420	1094	548	53	334	151	481	223	637	292	322	151	458	223	597	292
88	607	277	872	414	1154	541	582	277	825	414	1080	541	52	327	147	471	218	623	286	315	147	448	218	584	286
87	599	274	860	409	1139	533	574	274	815	409	1066	533	51	319	144	460	213	609	279	308	144	438	213	571	279
86	591	270	848	403	1124	526	566	270	804	403	1051	526	50	312	140	450	208	595	272	301	140	428	208	558	272
85	583	266	837	397	1108	518	559	266	793	397	1037	518	49	305	137	439	203	581	266	294	137	418	203	545	266
84	575	262	825	392	1093	511	551	262	782	392	1023	511	48	297	134	429	198	567	259	287	134	408	198	532	259
83	567	259	814	386	1078	504	543	259	771	386	1009	504	47	290	130	418	193	553	253	280	130	398	193	519	253
82	559	255	802	380	1063	496	536	255	760	380	994	496	46	283	127	408	188	539	246	273	127	388	188	506	246
81	551	251	791	375	1047	489	528	251	750	375	980	489	45	276	124	397	183	526	240	266	124	378	183	494	240
80	543	247	780	369	1032	482	520	247	739	369	966	482	44	268	120	387	178	512	233	259	120	369	178	481	233
79	535	244	768	363	1017	474	513	244	728	363	952	474	43	261	117	377	173	498	227	252	117	359	173	468	227
78	527	240	757	358	1002	467	505	240	717	358	938	467	42	254	114	367	168	485	220	245	114	349	168	455	220
77	519	236	745	352	987	460	498	236	707	352	924	460	41	247	111	356	163	471	214	238	111	340	163	443	214
76	511	232	734	347	972	452	490	232	696	347	910	452	40	240	107	346	158	458	208	232	107	330	158	430	208
75	503	229	723	341	957	445	483	229	685	341	896	445	39	233	104	336	154	444	201	225	104	320	154	418	201
74	495	225	712	335	942	438	475	225	675	335	882	438	38	226	101	326	149	431	195	218	101	311	149	405	195
73	487	221	700	330	927	431	468	221	664	330	868	431	37	219	98	316	144	418	189	212	98	301	144	393	189
72	479	218	689	324	912	424	460	218	654	324	854	424	36	212	94	306	139	405	183	205	94	292	139	380	183
71	472	214	678	319	897	417	453	214	643	319	841	417	35	205	91	296	135	391	177	198	91	282	135	368	177
70	464	211	667	313	883	410	445	211	633	313	827	410	34	198	88	286	130	378	171	192	88	273	130	356	171
69	456	207	656	308	868	402	438	207	622	308	813	402	33	191	85	276	125	365	165	185	85	264	125	344	165
68	448	203	644	303	853	395	431	203	612	303	799	395	32	184	82	267	121	352	158	179	82	255	121	332	158
67	440	200	633	297	838	388	423	200	601	297	786	388	31	178	79	257	116	340	153	172	79	245	116	319	153
66	433	196	622	292	824	381	416	196	591	292	772	381	30	171	76	247	111	327	147	166	76	236	111	307	147
65	425	193	611	286	809	374	408	193	580	286	758	374	29	164	73	238	107	314	141	159	73	227	107	296	141
64	417	189	600	281	795	367	401	189	570	281	745	367	28	158	70	228	102	301	135	153	70	218	102	284	135
63	410	185	589	276	780	360	394	185	560	276	731	360	27	151	67	219	98	289	129	146	67	209	98	272	129
62	402	182	578	270	766	353	386	182	549	270	718	353	26	144	64	209	94	276	123	140	64	200	94	260	123
61	394	178	567	265	751	347	379	178	539	265	704	347	25	138	61	200	89	264	117	134	61	191	89	248	117
60	387	175	557	260	737	340	372	175	529	260	691	340	24	131	58	190	85	251	112	128	58	182	85	237	112
59	379	171	546	254	722	333	365	171	518	254	677	333	23	125	55	181	81	239	106	121	55	173	81	225	106
58	372	168	535	249	708	326	358	168	508	249	664	326	22	119	52	172	76	227	101	115	52	165	76	214	101
57	364	164	524	244	694	319	350	164	498	244	650	319	21	112	49	163	72	215	95	109	49	156	72	203	95
56	357	161	513	239	679	312	343	161	488	239	637	312	20	106	47	154	68	203	90	103	47	147	68	192	90
55	349	157	503	234	665	306	336	157	478	234	624	306	19	100	44	145	64	191	84	97	44	139	64	180	84

Heating Power of the Optima and Optima+; in watts/meter for heat output per meter of panel (QVM); and in watts/pair for heat output per collector set (QVV); according to EN 14037 1-3.



Cooling capacity table for the Optima

Optima 2				Optima 3				Optima 4			
$\Delta T_{VE}$	$Q_{VM}$	$Q_{VM}$	$Q_{VM}$	$\Delta T_{VE}$	$Q_{VM}$	$Q_{VM}$	$Q_{VM}$	$\Delta T_{VE}$	$Q_{VM}$	$Q_{VM}$	$Q_{VM}$
30	223	335	446	20	143	214	286	10	67	100	133
29	215	323	430	19	135	203	270	9	59	89	119
28	207	310	414	18	127	191	255	8	52	78	104
27	199	298	398	17	119	179	239	7	45	68	90
26	191	286	381	16	112	168	224	6	38	57	76
25	182	274	365	15	104	156	208	5	31	47	62
24	174	262	349	14	96	145	193	4	24	36	49
23	166	250	333	13	89	133	178	3	18	27	35
22	159	238	317	12	81	122	163	2	11	17	23
21	151	226	302	11	74	111	148	1	5	8	11

Cooling capacities of the Optima; in watts/meter for the cooling capacity per meter of panel (QVM); according to EN 14037-4:2016.

3.2 Calculations of the actual power and mass flow of the orbit.

Name	Description	Calculation	Example
$Q_M$ (W)	Heat output per meter of panel.	W/m based on $\Delta T_{VE}$ from the heat release table on the previous page.	= 260 W
$Q_V$ (W)	Heat output per collector set.	W/mp based on $\Delta T_{VE}$ from the heat release table on the previous page.	= 123 W
$Q_B$ (W)	Heating capacity of a single track.	$Q_B = Q_M \times L_o + Q_V$	= 5200 W
Q (W)	Heating capacity of the entire installation.	$Q = Q_B \times nB$	= 15600 W
qmB (kg/h)	Mass flow of a single track.	$qmB = Q_B / (4185 \times \Delta T_{AR}) \times 3600$	= 894 kg/h

**Step 4 - Determine the required connection.**

The number of pipes through which the water must flow affects the pressure. To ensure turbulence and minimal pressure loss, the number of pipes must be tailored to the required data. The water in the pipes must be turbulent to ensure delivery. The following pages contain two tables: 4.2 gives an indication of the pressure drop per meter of pipe at the mass flow rate; in 4.3, you can check whether the mass flow rate per pipe is high enough for turbulence.

4.1 Determine the number of pipes based on mass flow and pressure drop.

Example and approach

Use the previously selected product type to find the maximum number of pipes for this product in Table 4.2. For the Optima 4+, the maximum number of pipes is 8; this number is tested first. Calculate the mass flow in the direction of flow for this number of pipes and test it; repeat if necessary.

In the example, the mass flow rate of the flow direction =  $qmS = qmB / nS = 894 / 8 = 111.8$  kg/h. Enter this value in graph 4.3. In the example, the return temperature is 40 °C  $Q_r$ ; at a mass flow rate of 111.8 kg/h, the result is above the line, which means that turbulence is present.

When there is no turbulence, we use the next highest number of pipes and test them. For the Optima 4+, the next highest number is:  $nS = 4$ . In this case, this is not necessary because a suitable option has already been found. Test the setup for the pressure drop of the product. With a track length of 20 m ( $L_o$ ) at a mass flow of 111.8 kg/h ( $qmS$ ) in the flow direction, graph 4.4 shows that the pressure drop per meter is approximately 100 Pa.

The projected pressure drop for the entire track =  $100 \times 20 = 2000$  Pa. For ease of calculation, this figure must be below 19 kPa. In this case, this is indeed the case. If this is not the case, the next number of pipes must be taken from step 4.1.2 above and tested again. As a result, a connection can be selected from graphs 4.3 and 4.4 after proper testing. The pages following these calculations show overviews of the connections that can be selected. In the example, the product is the Optima 4+, the number of pipes is 4, which results in a single option: connection 1621-1600. The final product in the example is therefore the Infra Aqua Optima 4+ with connection 1621-1600.

Tabel 4.2 The number of pipes in the flow direction based on product selection.

Optima 2 and Optima 2+	Optima 3 and Optima 3+	Optima 4 and Optima 4+
Connection 821-800; nS = 4	Connection 1221-1200; nS = 6	Connection 1622-1601; nS = 4
Connection 822-801; nS = 2	Connection 1223-1202; nS = 2	Connection 1624-1603; nS = 2
Connection 810-810; nS = 8	Connection 1211-1211; nS = 4	Connection 1621-1600; nS = 8
Connection 824-803; nS = 1	Connection 1210-1210; nS = 12	Connection 1621-1621; nS = 8
	Connection 1226-1205; nS = 1	Connection 1628-1607; nS = 1

Graph 4.3 Minimum mass flow required per return temperature.

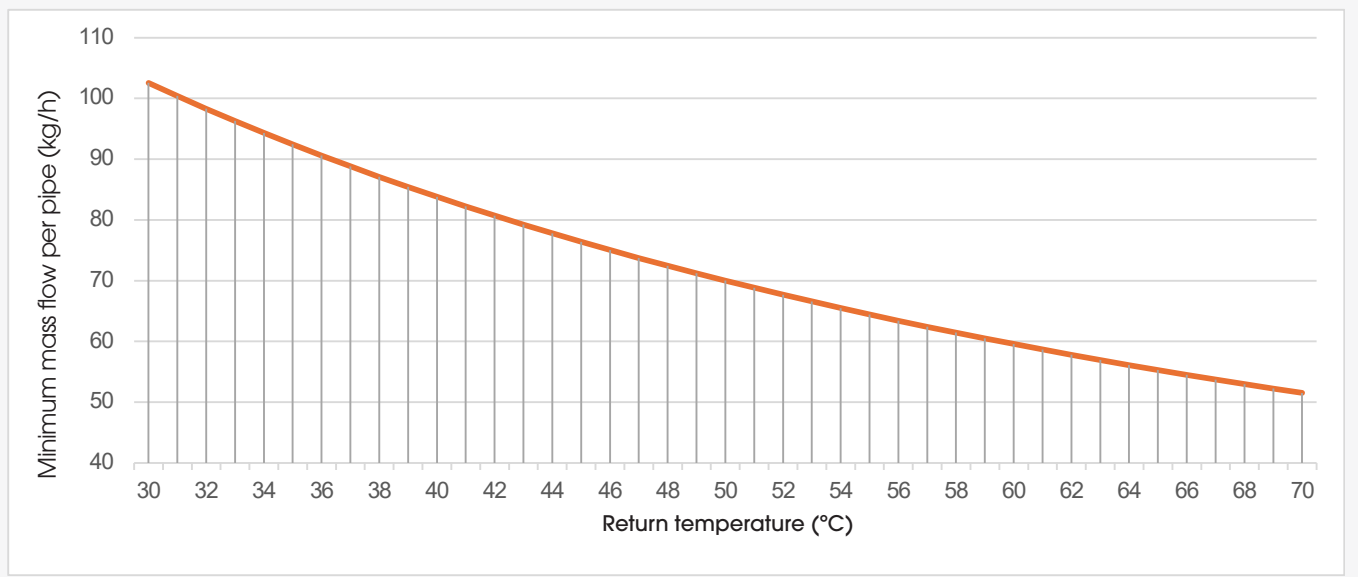

Graph 4.4 Pressure drop per meter per pipe at mass flow.

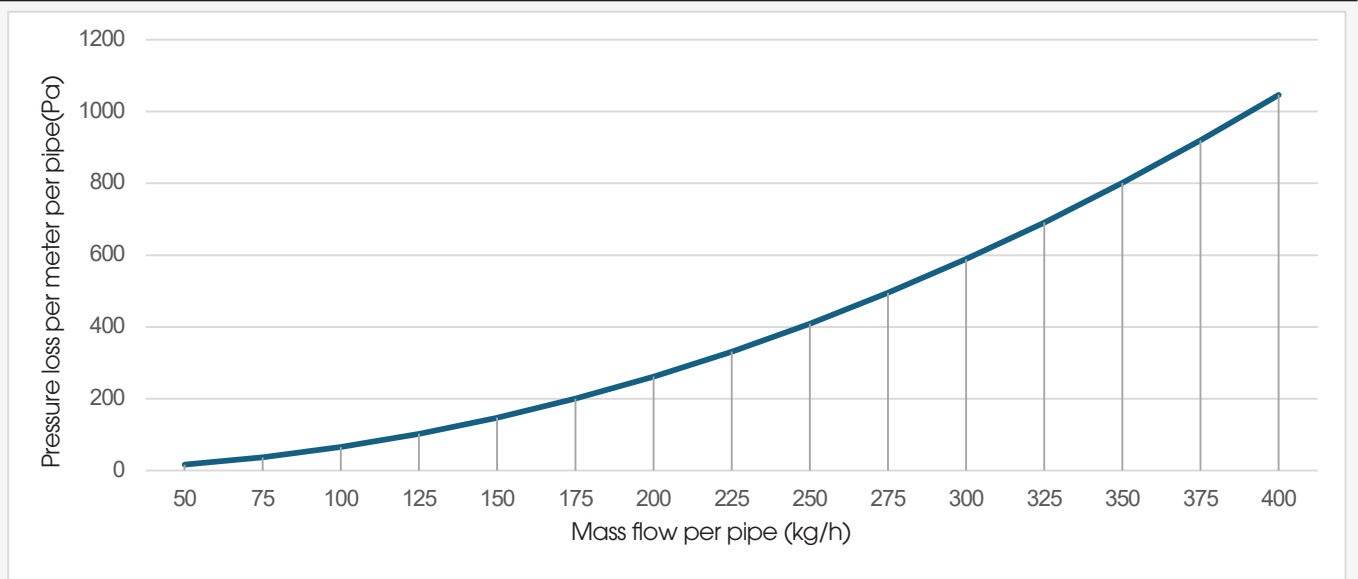

## Step 5 - Latest calculations and overview

5.1 Calculate the actual pressure loss of a track.

Name	Description	Calculation	Example
RP (Pa)	Pressure loss from the panels of a single track.	$RP = (qmS / 173) 2 * 196 * LO$	= 1638 Pa
RV (Pa)	Pressure loss of the collectors of a single track.	$RV = (qmB / 1000) 2 * 2000$	= 1598 Pa
R (kPa)	Total pressure loss of a single pass. Many heat exchangers have a limit of 20 kPa.	$R = (RP + RV) / 1000$	= 3.2 kPa

5.2 Overview of the installation's features

Name	Description	Calculation	Example
Q (W)	Heating capacity of the entire setup.	Calculated in step 3.2.	= 15.6 W
R (kPa)	Pressure loss from the track; the heat source must be able to supply this pressure.	Calculated in step 5.1.	= 3.2 kPa
product selection	Final product selection	Reasoned in step 4.4.	Optima 4+ 1621-1600

## Collectors

The Infra Aqua Optima and Optima+ collectors are made of durable steel and come with a 1" male connection for water and a 1/2" male connection for a vent.

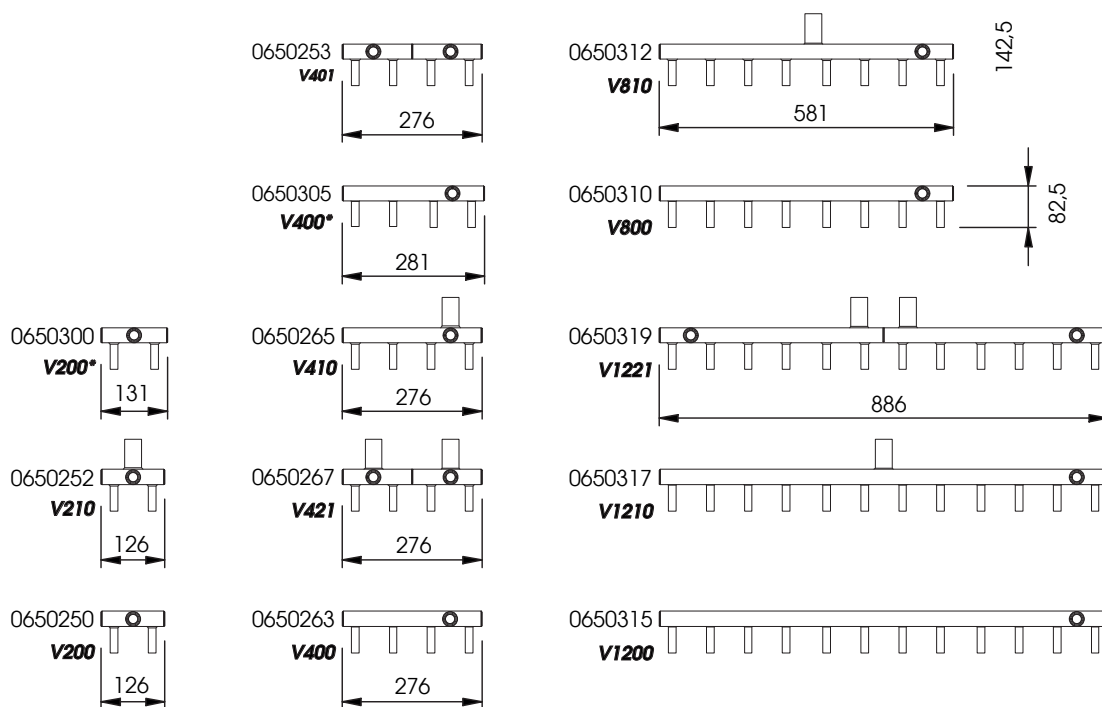

\* Collector with extra width compared to others of the same type, for bridges between individual segments.

## Connections of the Optima 2 / Optima 2+

The Optima 2 and Optima 2+ come standard with the following connection options:

Name	Characteristics
821-800	Medium lanes, low resistance.
822-801	Medium lanes, medium resistance.
810-810	Long lanes, low resistance.
824-803	Short lanes, high resistance.

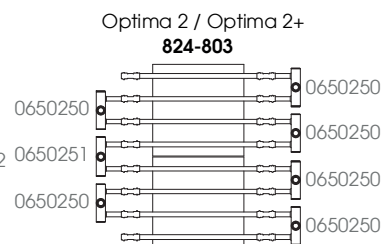
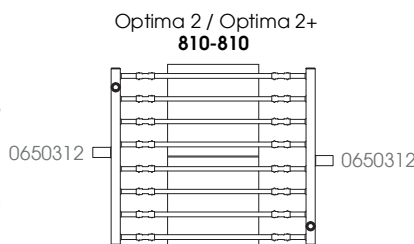
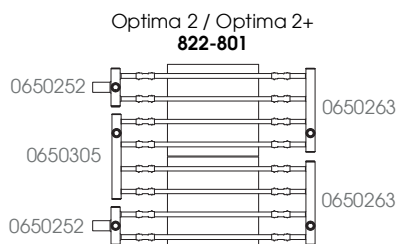
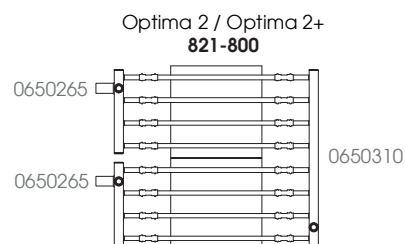



**Connections of the Optima 3 / Optima 3+**

The Optima 3 and Optima 3+ come standard with the following connection options:

Name	Characteristics
1221-1200	Medium lanes, low resistance.
1223-1202	Shorter lanes, medium resistance.
1211-1211	Medium lanes, medium resistance.
1210-1210	Long lanes, low resistance.
1226-1205	Short lanes, high resistance.

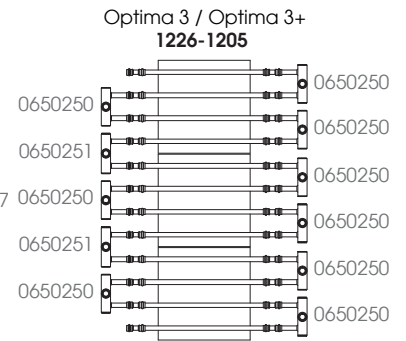
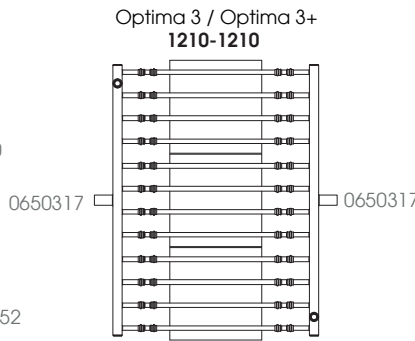
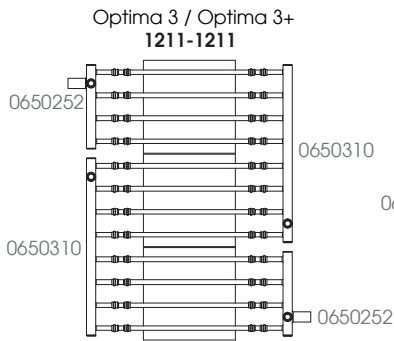
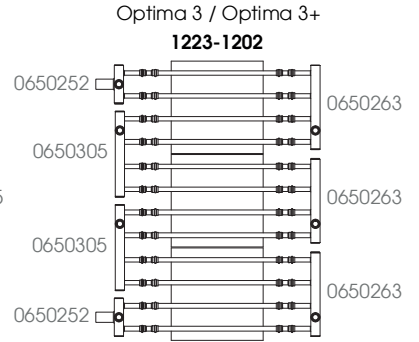
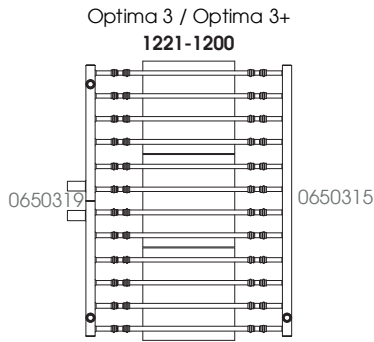

**Connections of the Optima 4 / Optima 4+**

The Optima 4 and Optima 4+ come standard with the following connection options:

Name	Characteristics
1622-1601	Medium lanes, low resistance.
1624-1603	Shorter lanes, medium resistance.
1621-1600	Medium lanes, medium resistance.
1621-1621	Long lanes, low resistance.
1628-1607	Short lanes, high resistance.

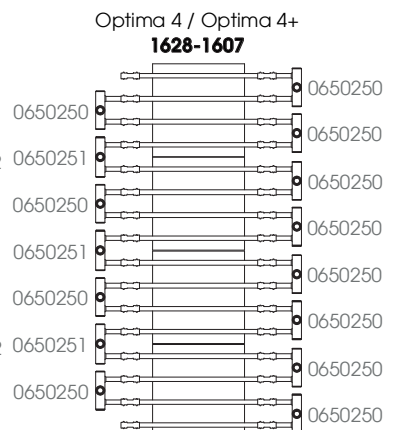
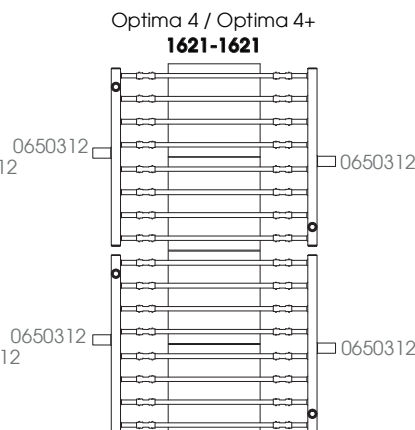
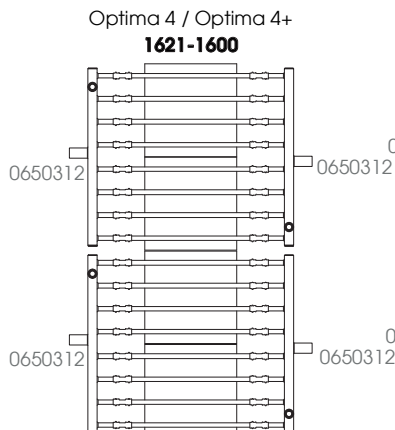
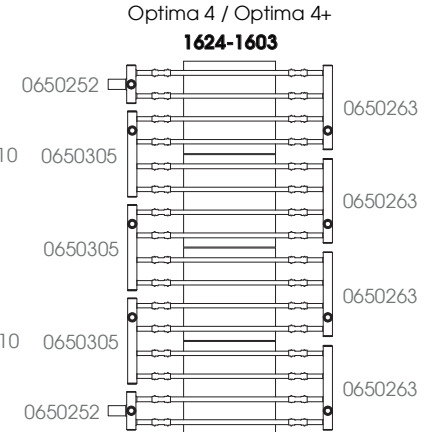
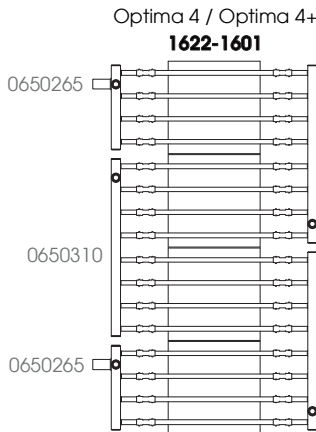

Connection options (and flow direction of the medium)

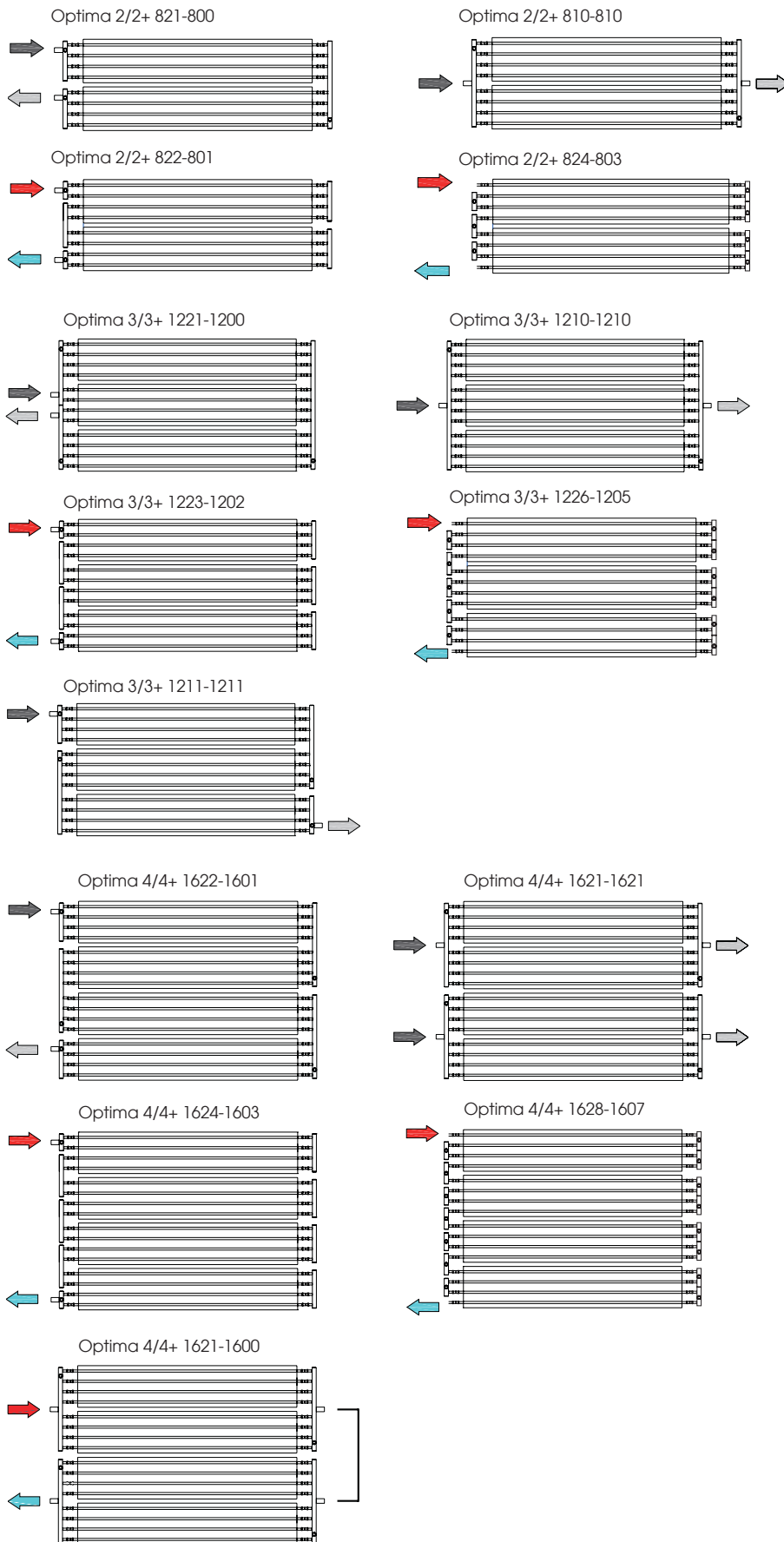

## Controls

### Water side

A low water content in the system and a relatively high flow rate of the heating medium result in excellent controllability of the installation. To maintain a constant design temperature, this must be regulated via the supply temperature of the heating medium, based on a mixing control system, which maintains turbulent flow in the pipes.

### Room temperature

The room temperature should preferably be controlled using a black globe sensor (see accessories).

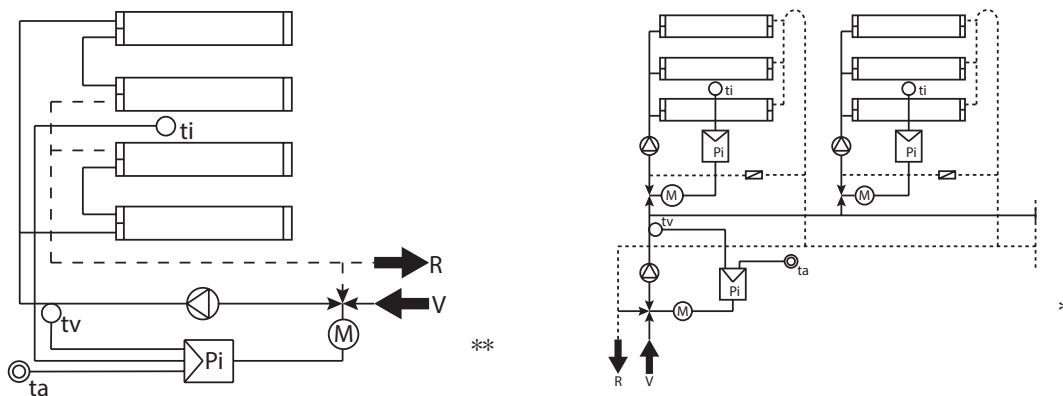

### Weather-dependent supply temperature control

The setpoint  $X_s$  of the outdoor temperature controller is shifted accordingly until the desired indoor temperature  $t_i$  is reached.

### Zone regulation

Example: a production area at 18 °C and a warehouse at 16 °C. Thanks to outdoor temperature control, it is possible to work with a higher supply temperature than is strictly necessary for each zone.

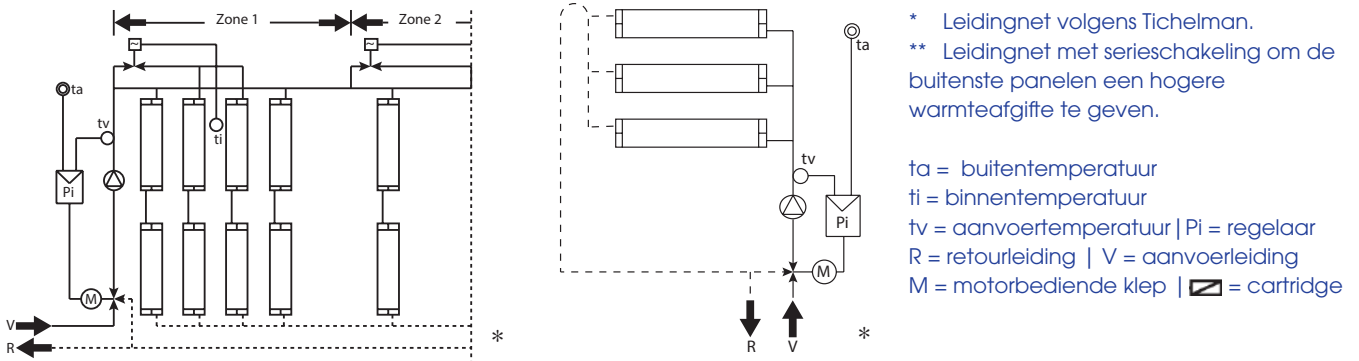

### Zone indoor temperature control

By switching radiant panels on and off, the supply temperature is controlled depending on the weather using a PI controller. A room thermostat controls a solenoid valve that shuts off part of the heating water as soon as the set temperature is exceeded. Multiple zones can be supplied by a single pump, with each zone comprising at least two groups. This control system is ideal for installations with high heat loads and for time-controlled temperature reductions, such as night and weekend reductions.

### Weather-dependent supply temperature control 2

Control (no regulation) of the indoor temperature  $t_i$  by the supply temperature  $t_v$ . Simplest solution, without feedback from the indoor temperature  $t_i$ .



A woman with long blonde hair, wearing a blue button-down shirt and black trousers, stands in a server room. She has her right hand on her hip and is holding a tablet in her left hand. The background shows rows of server racks.

**“80 years of  
climate control  
experience”**



# Ready to discover the future of climate control?

With the Infra Aqua Optima, you are choosing quiet, direct, and energy-efficient heat emission that is applied precisely where comfort is desired. Thanks to its high radiation efficiency and flexible applicability, the installation remains efficient in both commercial and industrial settings. From a single workstation to entire halls, the Optima offers a future-proof solution that is easy to integrate and expand.

Do you have a project or would you like to know which configuration best suits your situation? We are happy to help you. With free advice, detailed calculations, and an extensive product portfolio, Mark helps you create a pleasant indoor climate.



**mark**

**building climate technology**

**Mark Climate Technology**

Beneden Verlaat 87-89  
9645 BM Veendam  
Nederland

+31 (0)598 656612  
info@markclimate.com  
www.markclimate.com

**in** [www.linkedin.com/company/  
mark-climate-technology](http://www.linkedin.com/company/mark-climate-technology)