

**mark**

building climate technology

# Airstream

PLUG & PLAY HEAT RECOVERY UNIT

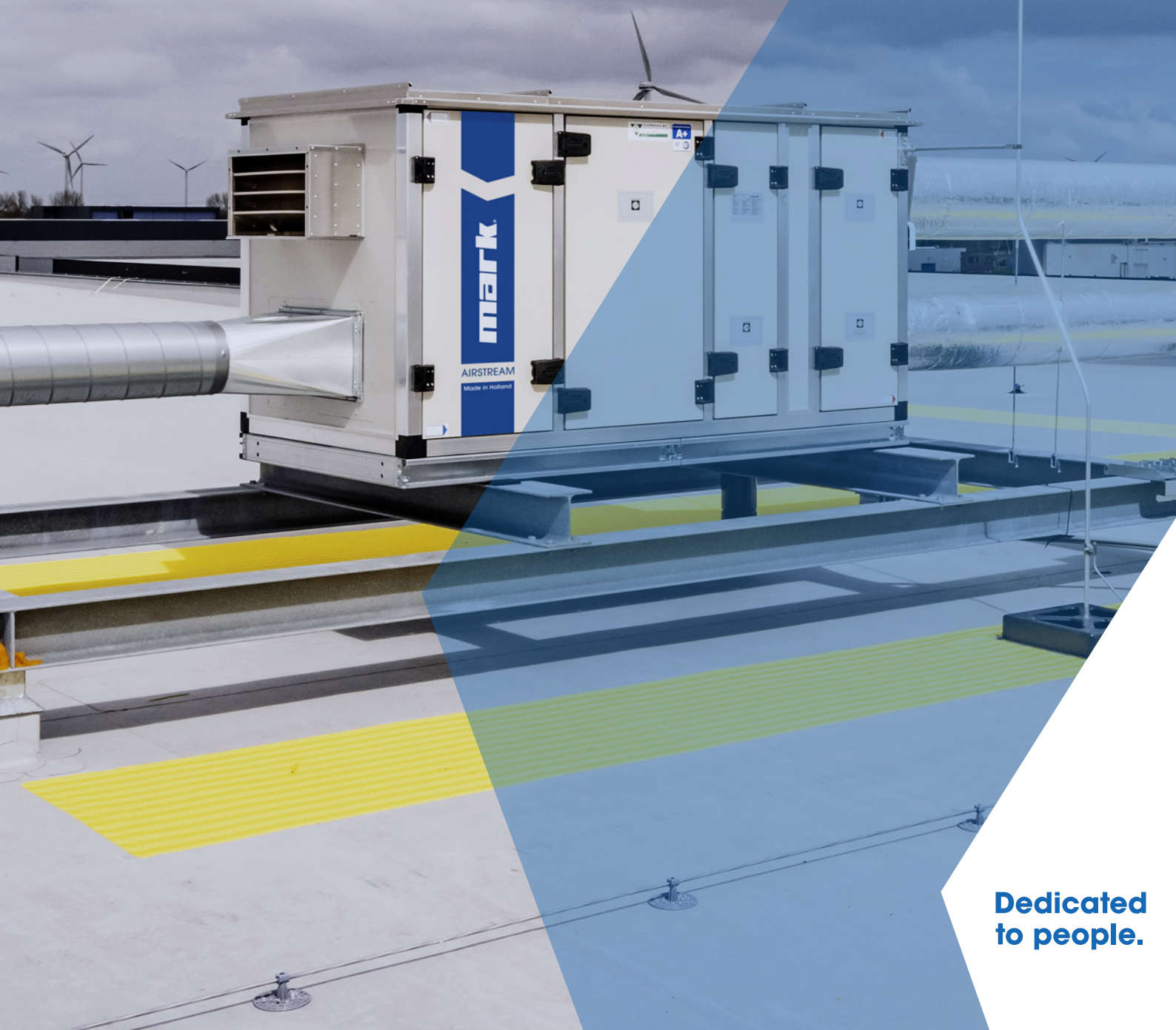

**Dedicated  
to people.**

# Mark Airstream

## PLUG & PLAY HEAT RECOVERY UNIT

Indoor air quality of buildings need to meet higher standards. In order to meet these requirements, intensive ventilation is needed. By applying basic ventilation equipment, a lot of energy is lost. To counteract the loss of energy, Mark has developed the AIRSTREAM. This heat recovery unit is equipped with a counter flow heat exchanger which has an efficiency of 90%. This means that 90% of the discharged energy is given back to the fresh supply air. Because of this high efficiency, no extra heating is needed in most cases.

The AIRSTREAM heat recovery unit is available for both indoor and outdoor installation purposes. We supply an AIRSTREAM with counterflow heat exchanger (CFX) or rotary heat exchanger (HWX). The AIRSTREAM is used in offices, schools, workshops and changing rooms.

Mark AIRSTREAM is certified according to Eurovent and RLT Richtlinie-01. In addition, by using the heat recovery unit the end user might qualify for local government grants. Please contact us for more details.

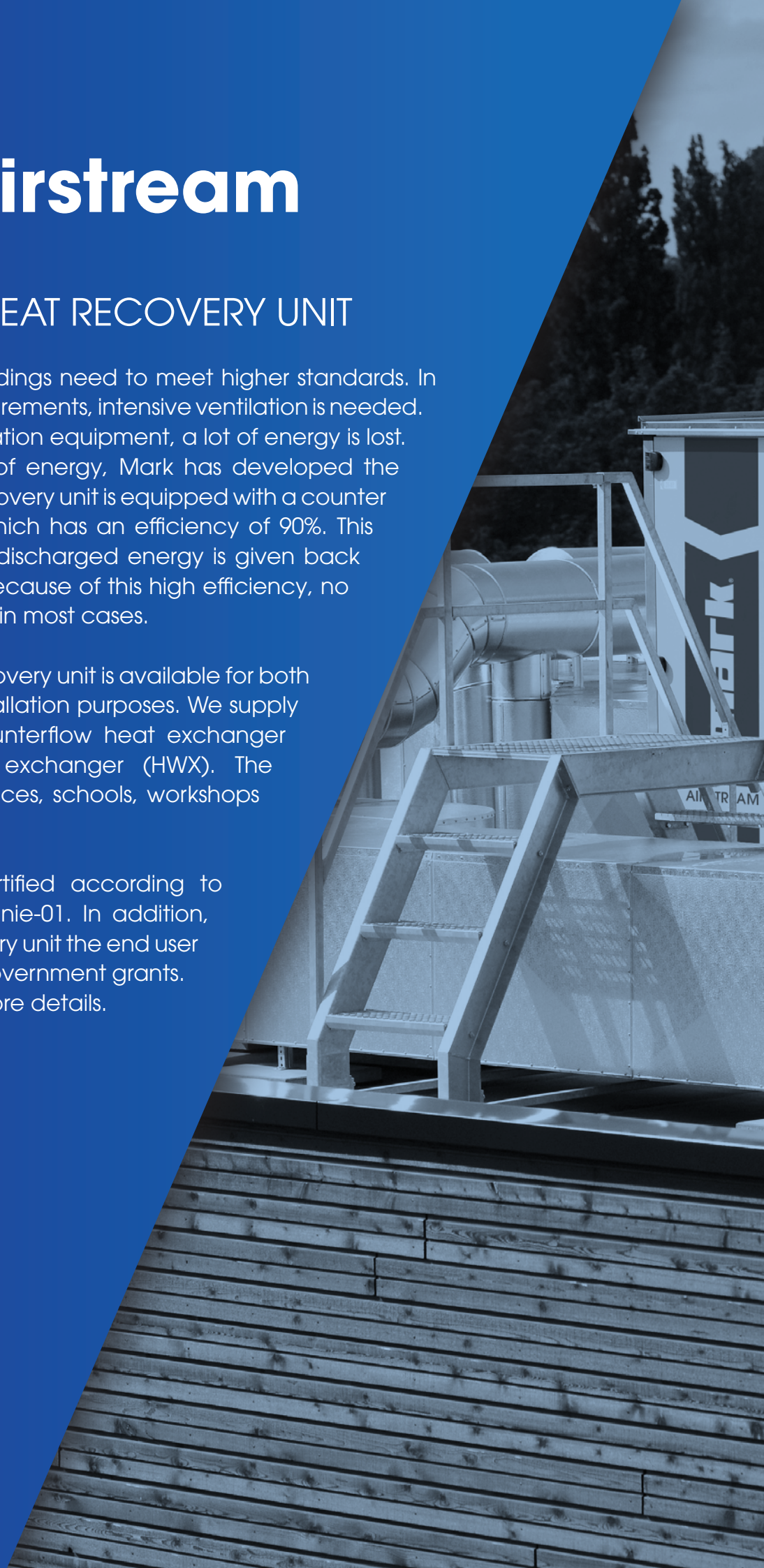



**Dedicated  
to people.**

## GENERAL DESCRIPTION AND APPLICATION

Mark AIRSTREAM is a high energy-efficient ventilation unit with heat recovery.

The AIRSTREAM CFX is equipped with a high efficiency aluminum counterflow heat exchanger for recovering exhaust energy. The exchanger is also equipped with a "bypass" and "face" damper to be able to ventilate during the summer, without recovering unwanted heat.

The AIRSTREAM HWX is equipped with a corrosion-resistant rotary heat exchanger made of seawater resistant aluminum. The unit is standardly equipped with a so-called sorption wheel. This heat wheel has a hygroscopic zeolite coating and is often used when cooling is required. The sorption wheel can transmit both heat and moisture. This reduces the required cooling capacity because the outside air is dried and cooled. The rotary heat exchanger has an available efficiency of 78% to 90%. The unit can also be fitted with an enthalpy wheel. This wheel is extremely capable of transmitting heat and limits moisture transfer.

The heat recovery unit is equipped with variable speed EC-fans, ISO ePM1>50% bag filters in the fresh air intake and ISO ePM10>50% bag filter in the exhaust air. The Airstream is provided with an integrated "plug and play" control system, which is also equipped with a built-in webserver so that the heat recovery unit can be remotely monitored.

Additional built in components, such as an outside air, recirculating air or exhaust air dampers, pre- or after-heaters and cooling coils are available as an option.

- Hot water battery
- Gas heater
- Cold water coil
- DX-cooling battery
- Change-over battery suitable for heat pump
- Electrical heating coil

The casing is constructed of thermal bridge-free aluminum profiles with plastic corner pieces and hygienic seals (according to VDI 6022 standards). The sandwich panels on the inside and outside are equipped with galvanized steel sheet with a thickness of 0.5 mm. The inner PU-sound and heat insulation is environmentally friendly expanded with water. The internal panelling is made of Magnelis ZM310 with a C4 corrosion resistance.



The outside is powder-coated with RAL 9002. The total wall thickness of the Airstream is 45 mm. The casing is very strong, heat-insulating and smooth on the inside.

The AIRSTREAM is mounted on a support frame in galvanized steel of 100 mm or 200 mm height. For transport, lifting plates or lifting beams can be ordered as an option. The outdoor installation is also equipped with a seawater-resistant aluminum (AlMg<sup>3</sup>) roof and intake / outlet hoods. The removable doors are equipped with adjustable plastic hinges and camlocks. The air direction is selectable when ordering. The quality of Mark-products is assured by the Quality Management System according to ISO-9001.

The combination of energy-efficient EC-motors with the high heat recovery factor (> 90%) of the heat exchanger guarantees a reduced cost of operation over the entire life of the device. If the boiler room is difficult to access, the unit can be supplied in sections. These sections can be assembled by the Mark service department\*. The Airstream units are delivered as plug and play.

All standard Mark AIRSTREAM types are certified according to Eurovent and the German RLT-01 directive and are designed according to the guideline VDI 6022. The AIRSTREAM is certified with RLT energy efficiency class A+, achieving the highest possible returns.

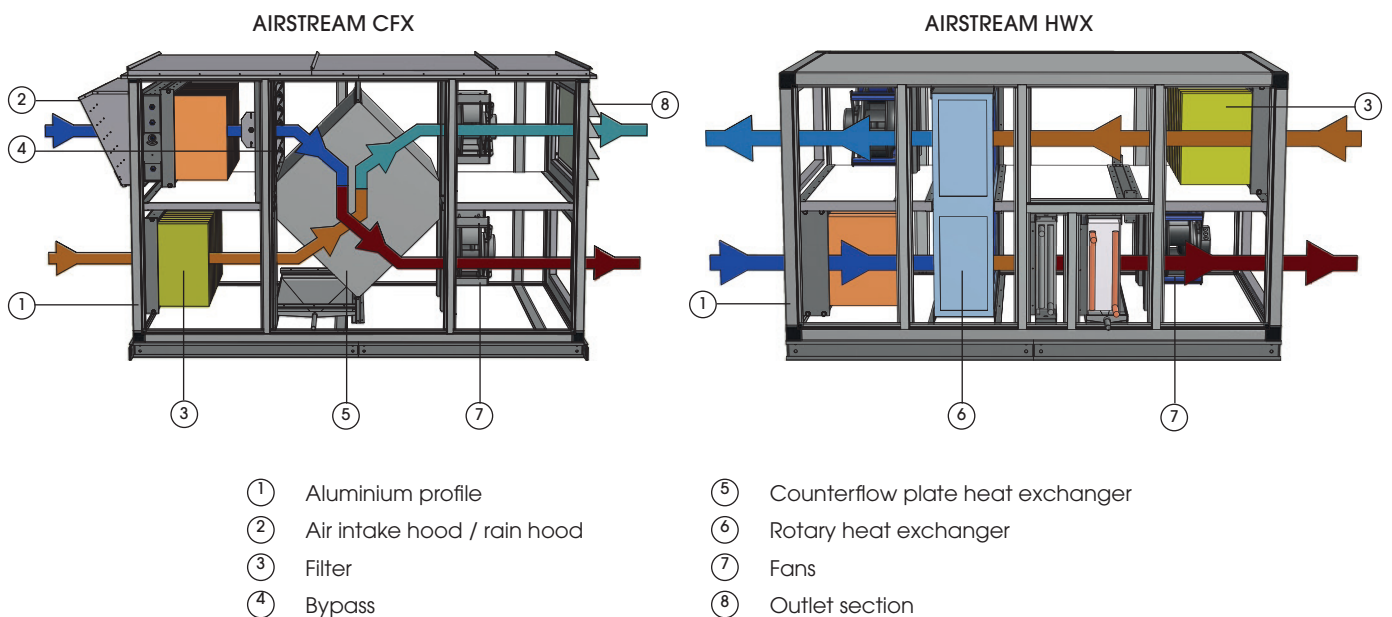



Mark AIRSTREAM is specially designed to supply fresh air as efficiently and comfortably as possible into the room that needs to be ventilated. The compact units are suitable for all types of buildings, for example for offices of all sizes, as well as schools, museums, theatres, cinemas, etc.

In order to design a good installation that meets the desired requirements and expectations, the parameters according to the standard NEN-EN 16798-1:2015 Energy Performance of buildings – Part 1 must be recorded and captured.

This standard describes the indoor environment-related input parameters for design and assessment of the energy performance of buildings for the quality of indoor air, thermal comfort, lighting, acoustics and the usage profile.

The agreements between client, architect, designer and installer must be recorded as such in accordance with NEN-EN 16798-1 and serve as the basis for the design. For the design of the indoor air quality, the national requirements laid down in Annex A or the standard values in Annex B must be taken into account.

According to Fanger’s comfort theory, the percentage of dissatisfied people can be determined as a result of the thermal indoor climate. This breakdown into Categorys is set out in the table below.

*Table 1 - Examples of recommended Categorys for design of mechanically heated and cooled buildings*

Category	Thermal state of the whole	
	PPD (%)	Predicted Mean Vote
I	< 6	-0.2 < PMV < + 0.2
II	< 10	-0.5 < PMV < + 0.5
III	< 15	-0.7 < PMV < + 0.27
IV	< 25	-1.0 < PMV < + 1.0

Recommended input values are given for each of the different Categorys. A brief description of the Categorys is shown in Table 2.

*Table 2 - Description of the applicability of the Categorys used*

Category	Description
I	High level of expectation: advised for areas in which people are sensitive and prone to certain illnesses. Handicapped, very small children or older people.
II	Standard expectations: advised for new construction and renovations.
III	Low level of expectation: to apply to existing buildings.
IV	Low level of expectation. This category should only be accepted for a limited part of the year.

To determine the minimum outside air volume flow two methods can be distinguished:

**METHOD 1: method based on perceived air quality**

The design ventilation amount is calculated on the basis of two components:

- (A) - ventilation to dilute / remove contamination of the occupants (bio effluents);
- (B) - ventilation to remove pollution from the building / to dilute systems.

The ventilation for each category is the sum of these two components, as illustrated in the equation below:

$$q_{tot} = n \cdot q_p + AR \cdot q_B \text{ Eq (1)}$$

$q_{tot}$  = total ventilation speed for the breathing zone, l / s

$n$  = design value for the number of people in the room

$q_p$  = ventilation rate for capacity utilization per person, l / (s \* person)

$AR$  = floor surface, m<sup>2</sup>

$q_B$  = ventilation rate for building emissions, l / (s, m<sup>2</sup>)

Table 3 - Design ventilation rate for non-adapted people for the dilution of emissions (bio-effluents) of people for different categories

Category	Expected percentage of dissatisfied	Air flow per non-adjusted person
		l / (s per person)
I	15	10
II	20	7
III	30	4
IV	40	2,5*

Table 4 - Design ventilation quantity for diluting emissions of different types of buildings

Category	Very low polluting building	Low polluting building	Non-low polluting building
	l / (s m <sup>2</sup> )	l / (s m <sup>2</sup> )	l / (s m <sup>2</sup> )
I	0,5	1,0	2,0
II	0,35	0,7	1,4
III	0,2	0,4	0,8
IV	0,15	0,3	0,6
Minimal total ventilation rate for health	4 l / s per person	4 l / s per person	4 l / s per person

Table 5 - Example of design ventilation volume for a single office of 10 m<sup>2</sup> in a low-polluting building (unadjusted person)

Category	Low polluting building	Air flow per non-adjusted person	Total design ventilation air flow for the room		
	l / (s m <sup>2</sup> )	l / (s per person)	l / s	l / (s per person)	l / (s * m <sup>2</sup> )
I	1,0	10	20	20	2
II	0,7	7	14	14	1,4
III	0,4	4	8	8	0,8
IV	0,3	2,5	5,5	5,5	0,55

The total ventilation volume must never be less than 4 l / s per person.

## METHOD 2: method using limit values for gas concentration

The design ventilation percentages are calculated on the basis of a steady-state mass balance equation for the concentration of pollutants in the room, taking into account the concentration of pollutants outside. If CO<sub>2</sub> is used as an indicator for human occupation, the standard limit values are taken from the table. Further recommended criteria for the CO<sub>2</sub> calculation are included in TR15251. The mentioned CO<sub>2</sub> values can also be used for demand-controlled ventilation.

Table 6 - Standard design CO<sub>2</sub> concentrations above outdoor concentration assuming a standard CO<sub>2</sub> emission of 20 L / (h per person)

Category	Corresponding CO <sub>2</sub> concentration above outdoors in PPM for non-adapted people
I	550 (10)
II	800 (7)
III	1350 (4)
IV	1350 (4)

If the employees and other attendees are the determining cause of dust loads in the room, the CO<sub>2</sub> concentration is a recognized standard for the assessment of air quality. Experience has shown that an increased CO<sub>2</sub> concentration has a negative effect on the attention span. The values in Table 6 are used to determine the CO<sub>2</sub> concentration in the room air and to take suitable measures. The measures taken to improve air quality within the air quality range between 1000 and 2000 ppm according to Table 6 must be documented in the risk assessment. This also applies if the measures fall below 1000 ppm CO<sub>2</sub> in the room air.

Table 7 - Recommendations according to ASR 3.6 Ventilation

CO <sub>2</sub> -concentration (ml/m <sup>3</sup> ) respectively (ppm)	Measures
<1000	No further measures (provided that the use of the room does not increase the concentration above 1000ppm)
1000-2000	<ul style="list-style-type: none"> <li>• Check and improve ventilation</li> <li>• Create a ventilation plan (for example, define responsibilities)</li> <li>• Ventilation measures (e.g. increase of outdoor air flow or air change)</li> </ul>
>2000	Further measures required (e.g. increased ventilation, reduction in the number of people in the room)

The outdoor air classification is shown in Table 8. These Categories are used to inform all parties involved about the external pollution and, in combination with the supply air classification Table 9, about the required filtration (Table 10) and air purification (Table 11).

Table 8 - Outdoor air quality (ODA = Outdoor Air)

Category	Description
ODA 1	Pure air that may only be dusty (pollen). All limit values set by the WHO are not exceeded.
ODA 2	Outside air with a high concentration of dust and particulate matter and / or gaseous contamination. The WHO limit values are exceeded by a maximum of 50%
ODA 3	Same as ODA 2, however the WHO limit value is exceeded by more than 50%.

The classification according to Table 8 must be performed separately for gaseous ODA (G) and ODA (P) pollutant particles.

The quality of the supply air for buildings under human occupation must take into account the expected emissions of internal sources (human metabolism, activities and processes, building materials, furniture) and the ventilation system itself to ensure that the correct indoor air quality is achieved.

NOTE: prEN 16798-1: 2015 provides more information about the use of “low-polluting materials” or “lowpolluting buildings”. The outdoor air speeds must be specified in the design of the system. If the supply air also contains recirculation air, this is also mentioned in design documentation. Only exhaust air of category ETA1 can be recirculated to the other rooms. Exhaust air of category ETA2 can be recirculated to the same room (see page 10). The air supply category is specified using Table 9.

Table 9: Classification of supply air

Category	Description
SUP 1	Same as ODA 2, however the WHO limit value is exceeded by more than 50%.
SUP 2	Supply air with a low concentration of fine dust or gases
SUP 3	Supply air with a low concentration of fine dust or gases
SUP 4	Supply air with a high concentration of fine dust or gases
SUP 5	Supply air with a very high concentration of fine dust or gases

The outdoor air filter must be selected in such a way that the requirements of the indoor air in the building are complied with taking into account the outdoor air category (Table 10 and Table 11). The dimensioning of filter sections must be the result of an optimization, taking into account the specific situation (run time, dust load, special local contamination situation, etc.).

Depending on the level of particulate pollution in the open air and the desired quality of the supply air, different levels of filtration are required. The required filtration efficiency can be achieved by using filtration with a single or multiple phase. It is the combined filtration efficiency of the complete filtration phase that determines whether the quality of the supply air has been achieved. To keep the ventilation system clean, the minimum combined filtration efficiency is specified in A.4.2 and B.4.2 in accordance with EN ISO 16890-1.

In cases where a supply air level of SUP 1 or 2 is required and where the outdoor air quality is based on gaseous components of level ODA 2 or ODA 3, it is recommended to complete the particle filtration with appropriate gas phase filtration (Table 11) to avoid harmful levels of CO, NOx, SOx, VOC and O3.

Table 11 below shows the required combined average filtration efficiency (EN ISO 16890-1) required to arrive at an ODA level to a desired SUP level:

Table 10 - Minimum filtration efficiency based on the quality of the outdoor air in the particles

Outdoor air quality	Supply air class				
	SUP 1	SUP 2	SUP 3	SUP 4	SUP 5
ODA (P) 1	88%	80%	80%	80%	Not specified
ODA (P) 2	96%	88%	80%	80%	60%
ODA (P) 3	99%	96%	92%	80%	80%

\* Combined average filtration efficiency with one or more phases in accordance with the average filtration efficiency specified in EN ISO 16890-1.

Table 11 - Recommended minimum filter classes per filter section (definition of filter classes according to EN ISO 16890-1)

Outdoor air quality	SUP 1	SUP 2	SUP 3
ODA 1	ISO ePM10>50% + ISO ePM1>50%	ISO ePM1>50%	ISO ePM1>50%
ODA 2	ISO ePM2,5>65% + ISO ePM1>50%	ISO ePM10>50% + ISO ePM1>50%	ISO ePM10>50% + ISO ePM1>50%
ODA 3	ISO ePM1>50% + ISO ePM1>80%	ISO ePM2,5>65% + ISO ePM1>50%	ISO ePM2,5>65% + ISO ePM1>50%

In order to maintain a good sanitary level in the ventilation system, the minimum combined filtration efficiency of mechanical supply air must comply with filtration class ISO ePM1>50% in accordance with EN ISO 16890-1.



## Standards & Classification

There are many standards and guidelines in the field of air-conditioning and air handling units. The most important standards are briefly explained below:

### **NEN-EN 1886**

This standard deals with the mechanical properties of the air handling unit. To a number of these features a classification is assigned. For other features, performance requirements are valid. A classification applies to the deflection of panels in case of under and over pressure, leakage from the casing in under and over pressure situations, heat transfer and thermal bridges. A performance requirement applies to air leakage around the filter and for the fire safety of materials used.

### **NEN-EN 13053**

This standard covers the components in the air treatment unit and a classification depends on the efficiency of a number of these components. Other components are subjected to a performance requirement. A classification is valid for the air velocity through the air handling unit, the efficiency of the fan, the efficiency of the heat recovery equipment and the effectiveness of the mixing sections. A performance requirement is valid for the maximum air velocity through the inlet section in connection with ingress of water, installation and cleanability of coolers and droplet separators, installation of drip trays, humidifiers, filters and silencers.

### **VDI 6022 deel 1**

This publication (not standard) of the Association of German Engineers gives recommendations to make sure the conditioning process proceeds as clean as possible. That means paying attention to filters, empty corners, humidifiers and coolers. It also displays recommendations for cleaning, maintenance and industry-specific issues (especially for tobacco, paper, wood and textile industry).

### **EU 1253**

A standard which is set by the European Parliament regarding requirements concerning ecologic design for ventilation units. Air handling units (supply and exhaust units) with an air amount exceeding 1.000 m<sup>3</sup>/h must be fitted with an adjustable heat recovery system with a specified minimum efficiency. This installation also has to include a fan which is speed-controlled so that the SFP (specific fan power) limits are not exceeded. With these new requirements, the European Commission aims to limit the maximum power consumption of ventilation systems in buildings considerably. The Mark AIRSTREAM heat recovery unit has been certified according to Eurovent and the RLT Directive-01 and thus automatically complies with the EU directive 1253.



## Classification of the Mark Airstream

### Mechanical stability (DIN EN 1886)

Class	Max. deflection (mm/m)	Quality
<b>D1</b>	<b>4</b>	<b>+</b>
D2	10	-
D3	> 10	-

### Leakage through the casing at negative pressure (DIN EN 1886)

Class	Max. air leakage rate at 400 Pa test pressure	Filter class according to EN ISO 16890-1 (l/(sm <sup>2</sup> ))	Quality
<b>L1</b>	<b>0,15</b>	<b>ISO ePM1&gt;80%</b>	<b>+</b>
L2	0,44	ISO ePM1>70%	-
L3	1,32	Coarse filter	-

### Bypass Leakage max. applicable filter class (DIN EN 1886)

Class	Max. filter bypass leakage k in % of the airflow	Quality
<b>ISO ePM1&gt;80%</b>	<b>0,5</b>	<b>+</b>
ISO ePM1>70%	1	-
ISO ePM1>50%	2	-
ISO ePM2,5>50%	4	-
Coarse filter	6	-

### Exhaust air class (DIN EN 16798-3)

Category	Description
ETA1	Exhaust air with low levels of pollution
<b>ETA2</b>	<b>Exhaust air with a moderate level of pollution</b>
ETA3	Exhaust air with high levels of pollution
ETA4	Exhaust air with a very high level of pollution

### Thermal transmission U according to DIN EN 1886 - 1998 and pr EN 1886

Class	The heat transfer coefficient (W x m <sup>-2</sup> x K <sup>-1</sup> )	Quality
T1	$U \leq 0,5$	<b>+</b>
<b>T2</b>	<b><math>0,5 &lt; U \leq 1,0</math></b>	-
T3	$1,0 < U \leq 1,4$	-
T4	$1,4 < U \leq 2,0$	-
T5	no requirements	-

### Thermal cold bridge factor kb according to DIN EN 1886 - 1998 and prEN 1886

Class	Thermal bridging factor $K_b$		Quality
	DIN EN 1886 - 1998	prEN 1886	
TB1	$0,75 < k_b \leq 1,0$	$0,75 \leq k_b < 1,0$	<b>+</b>
<b>TB2</b>	<b><math>0,60 &lt; k_b \leq 0,75</math></b>	<b><math>0,60 \leq k_b &lt; 0,75</math></b>	-
TB3	$0,45 < k_b \leq 0,60$	$0,45 \leq k_b < 0,60$	-
TB4	$0,30 < k_b \leq 0,45$	$0,30 \leq k_b < 0,45$	-
TB5	no requirements	no requirements	-

Bold text is class that applies to the Mark AIRSTREAM.



## Energy efficiency class according to Eurovent

In addition to the EUROVENT-classification, the AIRSTREAM heat recovery units are also certified according to the RLT-Direction-01. EUROVENT and RLT are similar organizations that aim to give a transparent picture of the air handling units offered by the supplier. RLT Richtlinie-01 mainly focuses on the German market.



The energy efficiency class for RLT-approved air handling units is based on the DIN EN 13053: 2012, in which the air velocity, power uptake of the motors and heat recovery of the diagonal heat exchanger are defined. If the specific requirements within a class are met, the certification follows.

The Mark AIRSTREAM has been tested and certified by the TÜV Süd and has received the A+ certificate based on the measurements. With this certificate, consultants, end users and installers are assured that they operate with the highest quality ventilation units.

Product versions / Classes	A+	A	B
Without thermodynamic air	V5	V6	V7
With air heating	V4	V5	V6
With additional features	V2	V3	V5
Electric power consumption fan	P2	P3	P4
Heat recovery	H1	H2	H3

Air velocity through the cross-section of the air handling unit according to (EN 13053), measured over the filter		
Class	Air velocity in the unit (m/s)	Quality
<b>V1</b>	<b>&lt; 1,6</b>	
V2	> 1,6 tot 1,8	A+
V3	> 1,8 tot 2,0	A
V4	> 2,0 tot 2,2	
V5	> 2,2 tot 2,5	B
V6	> 2,5 tot 2,8	
V7	> 2,8 tot 3,2	
V8	> 3,2 tot 3,6	
V9	> 3,6	

Classes for electrical power consumption of the fan drive (EN 13053)		
Class	Energy efficiency $n_{e,1-1}$ (%)	Quality
P1	$\leq P_{m,ref} \cdot 0,85$	
<b>P2</b>	$\leq P_{m,ref} \cdot \mathbf{0,90}$	<b>A+</b>
P3	$\leq P_{m,ref} \cdot 0,95$	A
P4	$\leq P_{m,ref} \cdot 1,00$	B
P5	$\leq P_{m,ref} \cdot 1,06$	
P6	$\leq P_{m,ref} \cdot 1,12$	
P7	$\leq P_{m,ref} \cdot 1,12$	

$$P_{m,ref} = (\Delta P_{stat} / 450)^{0,925} \cdot (qv + 0,08)^{0,95}$$

$P_{m,ref}$  (kW) electric power consumption  
 $\Delta P_{stat}$  (Pa) Static pressure increase  
 $qv$  (m<sup>3</sup>/s) air flow

Heat recovery class (DIN EN 13053)		
Class	Energy efficiency $n_{e,1-1}$ (%)	Quality
<b>H1</b>	$\geq \mathbf{71}$	<b>A+</b>
H2	$\geq 64$	A
H3	$\geq 55$	B
H4	$\geq 45$	
H5	$\geq 36$	
H6	no requirements	
$n_e$	$= n_t \cdot (1 - 1 / \dots)$	
$n_e$	(%) Efficiency	
$n_t$	(%) Transfer degree in dry conditions	
(-)	Power rating	

Bold text is class that applies to the Mark AIRSTREAM.

## Energy efficiency class according to Eurovent

The entire range Mark AIRSTREAM heat recovery units are certified according to Eurovent. This European energy label for air handling units classifies an AHU on various aspects based on the European norms NEN-EN 1886 (mechanical performance) and NEN-EN 13053 (rating and performance).



To make sure all suppliers use the same test method and, above all, maintain their quality, they are subject to a review by Eurovent. Companies are regularly audited whether they still meet the measured reporting figures. This way, the customer is always guaranteed of a high quality product.

The following mechanical characteristics according to NEN-EN 1886 are certified:

- Casing strength
- Casing air leakage
- Filter bypass leakage
- Thermal transmittance of the casing
- Thermal bridging factor
- Acoustical insulation of casing

The following nominal ratings and performances according to NEN-EN 13053 are certified:

- Air flow - Available static pressure - power input
- Octave band in-duct sound power level
- Airborne sound power level
- Heating capacity
- Cooling capacity
- Heat recovery
- Pressure loss on water side

Class	All units		Units that operate with full or partial outside air with a winter temperature of <9°C		
	Speed		Heat recovery system		Efficiency fan
	$V_{Class}$ (m/s)	$n_{Class}$ (%)	$\Delta P_{Class}$ (Pa)	$NG_{ref-Class}$ (-)	
A+	1.4	83	250	64	
A	1.6	78	230	62	
B	1.8	73	210	60	
C	2.0	68	190	57	
D	2.2	63	170	52	
E	no requirements				

# AIRSTREAM CFX

## High efficiency counterflow plate heat exchanger

The AIRSTREAM CFX is equipped with a counterflow heat exchanger for exchanging the sensible and latent heat energy. The supply and exhaust air flows are completely separated.

The plate material is made of a corrosion-resistant aluminum alloy. High efficiencies are obtained thanks to the special plate structure (80-85% dry efficiency, > 90% wet efficiency). Class H1 according to EN 13053. The heat exchanger is equipped with a bypass and face-damper. The dampers are equipped with an integrated fully modulating 24V actuator.

## Bypass

Mark AIRSTREAM CFX counterflow heat exchanger is equipped with a bypass damper. After complete opening of the bypass damper all the air will go through the bypass, making sure there is no "leak" over the counterflow heat exchanger. This way there is no temperature exchange between the exhaust air and fresh air.

To avoid unnecessary heating of the air in the summer, the bypass damper is opened and the damper to the counterflow heat exchanger is closed. With this damper position free cooling can be created. In case of free cooling the fresh cool air is blown directly into the room. The air tightness of the bypass damper is class 2 according to DIN EN 1751 (higher classes available on request).

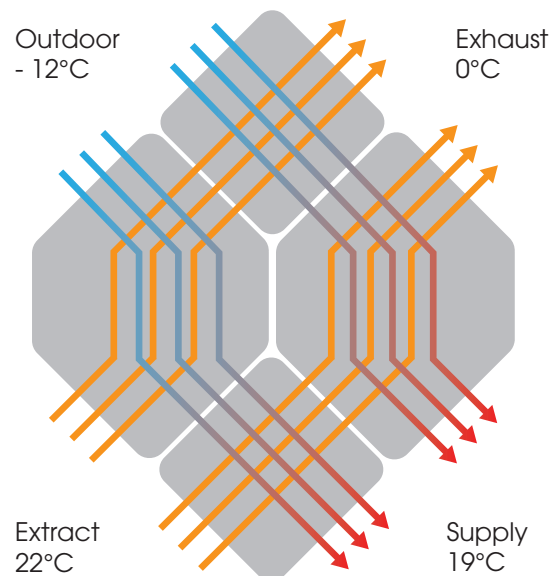

# AIRSTREAM HWX

## High efficiency rotary heat exchanger

Mark AIRSTREAM HWX is equipped with a rotary heat exchanger with available efficiencies from 78% to 90%.

### Features:

- Minimum freezing risk
- Short dimensions
- Heat and humidity recovery
- Highly suitable for variable air flows
- Adjustable heat recovery

### Material description:

Corrosion-resistant rotary heat storage mass made of seawater resistant aluminum foil.

### Configuration:

Condensation rotor developed for sensible heat recovery. Latent heat recovery takes place only when the discharge air is cooled below the dew point.

The rotary energy recuperator is built into the Airstream HWX. The upper half is located in the exhaust air and the lower half in the fresh air portion. The wheel is driven by a low speed electric motor which is controllable by means of frequency control. The aluminum structure of the wheel can be hygroscopic to enable recovery of the humidification. This results in an indoor climate that is perceived as less dry.



# CABINET STRUCTURE

## Panels

The Mark AIRSTREAM consists of a self-supporting frame of extruded aluminum profiles and reinforced polypropylene corners. This creates a stable frame structure.

The wall panels are double-walled panels (thickness 45.5 mm) with an inner cladding of Magnelis ZM310 with a C4 corrosion resistance and an outer cladding of coated and zinc-plated steel (thickness 0.5 mm) in the color RAL 9002 (Other colors available on request at extra cost). The panels are provided with PUR-insulation with a density of 45 kg/m<sup>3</sup> and a thermal conductivity of 0.024 W/mK. This makes for a very high thermal insulation. The insulation is non-combustible according to the NEN-EN 13501-1, class B-s2, d0.

The PUR-foam is expanded through water in an environmentally friendly way. This patented Hydrotec technology for the expansion of the polyurethane foam meets all European directives in the context of the elimination of fluorinated hydrocarbons in the future. In other words, this prevents the greenhouse

effect (GWP = 0) and the influence on the ozone layer present in the atmosphere (ODP = 0). The sound reduction of the panels is 36.1 dB at 8000 Hz. The sound reduction of the entire air handling unit is shown in the table below.

Air/noise insulation							
Frequency (Hz)	125	250	500	1000	2000	4000	8000
Air/sound insulation (dB)	9,5	11,7	10,6	13,0	12,1	24,0	43,3

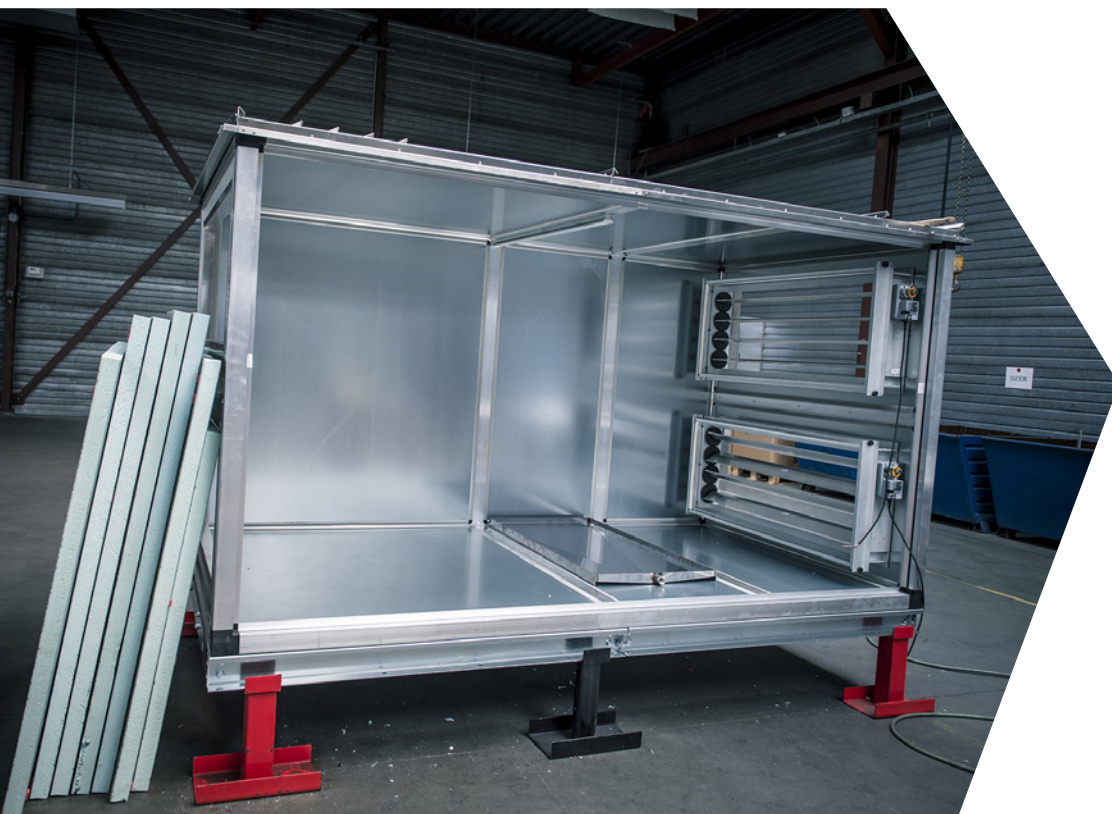

## Inspection doors

The inspection doors are fitted with plastic hinges (1) and closures (2). For opening and closing of the doors, the closures must be unlocked with the supplied key. After this the closure can be opened easily. Because the hinges and closures can be released, every door can be removed as a panel.

The externally mounted hinge fittings allow a completely smooth interior which prevents dirt accumulation in the unit. The airtight closure of the doors in relation to the housing is ensured by a special hygienic rubber profile according to ISO 846.

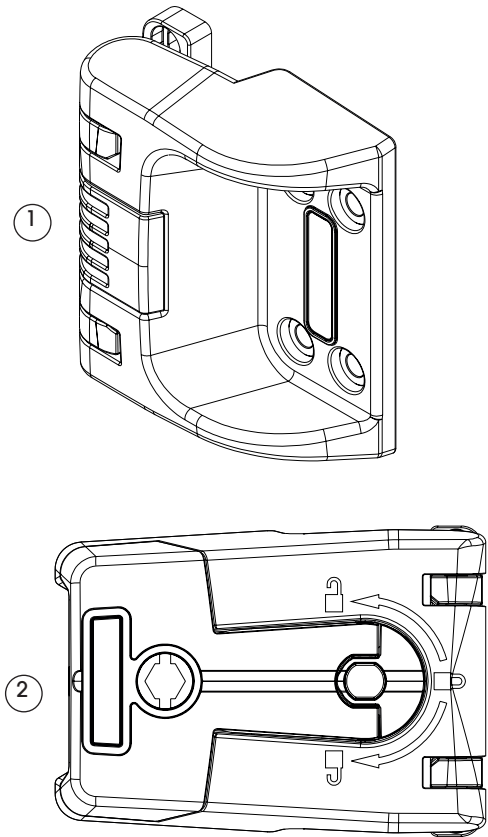

## Filters

The applied filters are of high quality and easy to exchange. The return air filter with a class ISO ePM10>50% (according to EN ISO 16890-1) protects the unit from contamination. The filter material is synthetic and temperature resistant.

The outside air intake is equipped with a class ISO ePM1>50% filter. Mark heat recovery units are equipped with standard filters, filter sizes and regular bag filters. This too reduces operating costs. The filters are selected in such a way, that in normal office use, a filter inspection once every six months is enough. Density filter class L1 (M) according to DIN EN 1886. The filters can be slid on the operating side in a metal filter frame.

To seal the filter frames and filters the necessary care is taken. Among the filters, a drip pan made of stainless steel 304 including drain will be installed.

### A comparison of the EN779 and ISO 16890 classes

A simple comparison of the classes from ISO 16890-1 to EN779: 2012 is not possible because very different measurement and evaluation methods are used. As a guideline we offer the following table:

Filter class according to EN 779	ISO ePM1	ISO ePM2.5	ISO ePM10	ISO Groffilter
G3	-	-	-	> 80 %
G4	-	-	-	> 90 %
M5	-	-	> 50 %	-
M6	-	50 - 65 %	> 60 %	-
F7	50 - 65 %	65 - 80 %	> 85 %	-
F8	65 - 80 %	> 80 %	> 90 %	-
F9	> 80 %	> 95 %	> 95 %	-



### Recommended filter class

Outside air quality	SUP 1	SUP 2	SUP 3
ODA 1	ISO ePM10>50% + ISO ePM1>50%	ISO ePM1>50%	ISO ePM1>50%
ODA 2	ISO ePM2,5>65% + ISO ePM1>50%	ISO ePM10>50% + ISO ePM1>50%	ISO ePM10>50% + ISO ePM1>50%
ODA 3	ISO ePM1>50% + ISO ePM1>80%	ISO ePM2,5>65% + ISO ePM1>50%	ISO ePM2,5>65% + ISO ePM1>50%

The Mark AIRSTREAM is equipped with ISO ePM1>50% bag filters in the supply air and ISO ePM10>50% filters used in the exhaust air as standard. Higher filter classes are available on request.

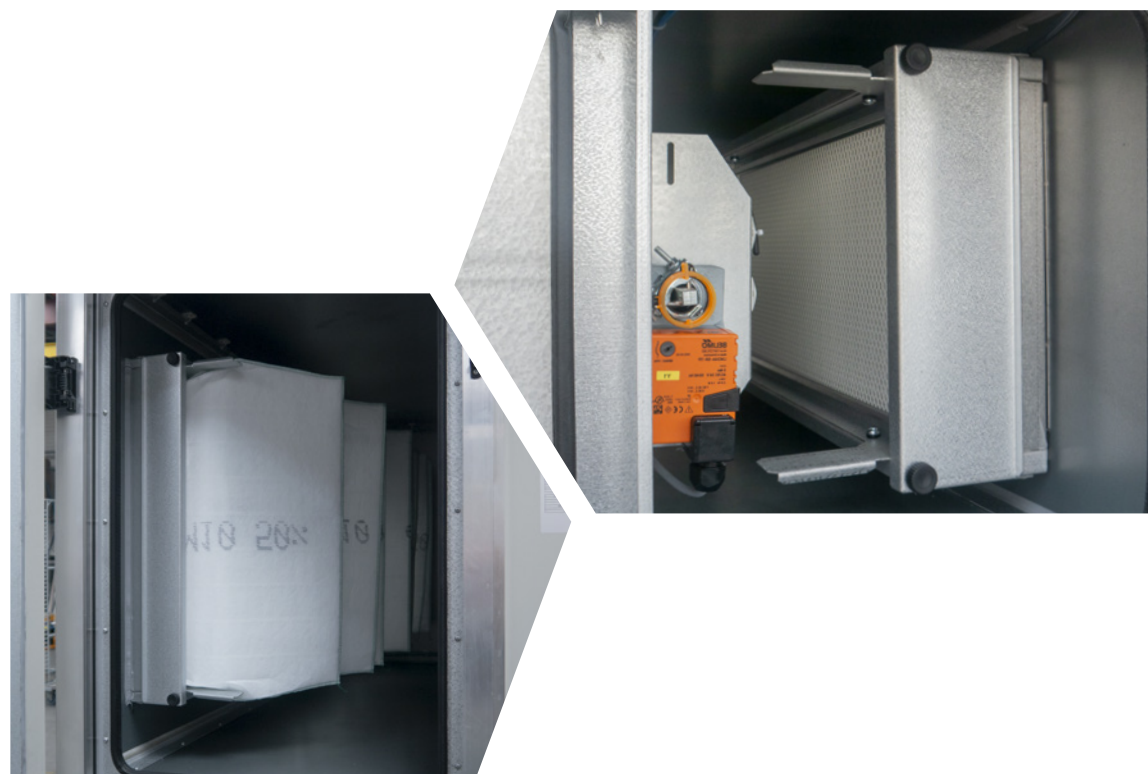

## Fans

The Mark AIRSTREAMs are supplied with plug fans with fully adjustable and energy efficient EC-motor technology. EC-technology stands for electronically commutated DC (direct current) motors. The fans are optimally selected for the specific operating point so that the lowest possible sound level and energy consumption is realized.

### Advantages of EC-technology DC-motors are:

- The highest efficiency at speed control
- Up to 50% energy savings at partial load
- Almost linear adjustable from 10-100%
- Long-life
- Silent
- Integrated electronic protection against overheating

For all standard AIRSTREAM heat recovery units the fans applied are in accordance with DIN EN 13053 and meet P2. The specific fan power for all standard AIRSTREAM heat recovery units comply with DIN EN 13779 to SFP3.

The motor-fan group is statically and dynamically balanced according to DIN ISO 1940. The smaller AIRSTREAM types have a 230V connection. The larger types have a connection of 3x 400V + N. Integrated PID controller for fully modulating power control (10-100%).

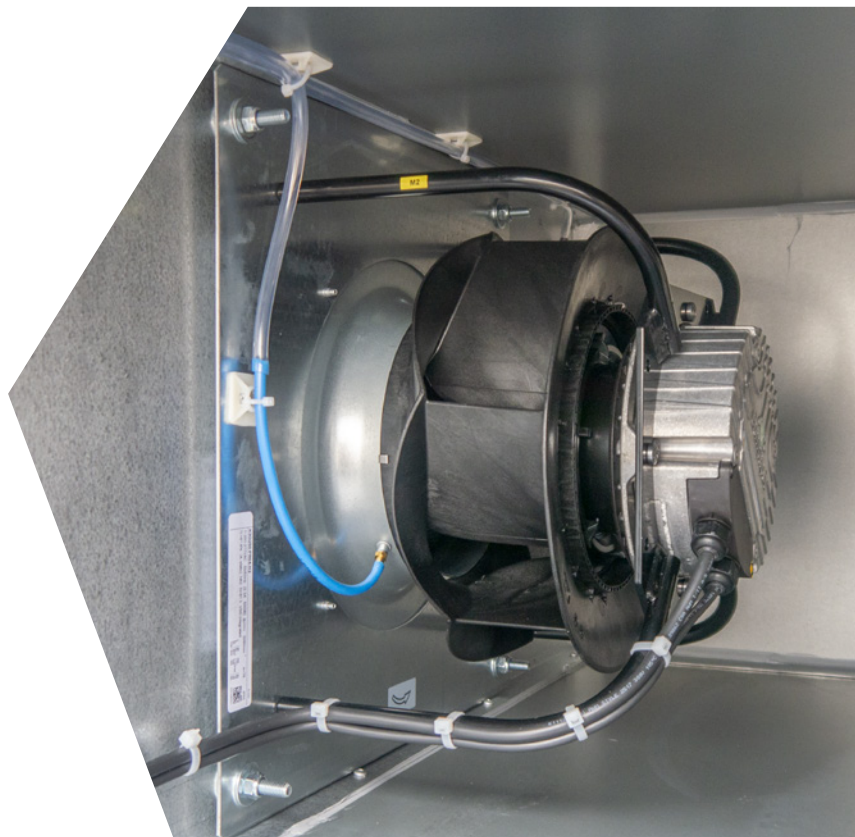
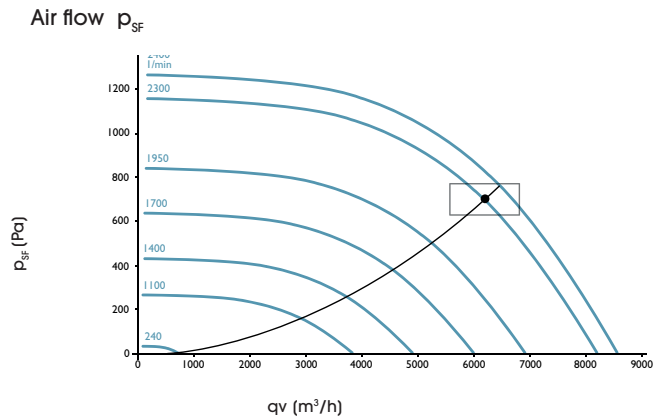



## After-heater / -cooler

Hot water coils are equipped with copper pipes, aluminum fins and steel collectors and are suited for pressures of 4-5 bar. The header connections of the heat exchanger can be positioned in- or outside the structure of the air handling unit.

Available options:

- Hot-dip galvanized heat exchanger
- Corrosion-resistant coating on the heat exchanger
- Steam / thermal oil heat exchanger
- Frost protection thermostat

On the operating side of the AIRSTREAM is an inspection hatch for inspection and cleaning of the heating or cooling coil. The default room temperature for selecting a heat exchanger is 22 °C. The number of tube rows in the heat exchanger is determined as a result of the requested design temperatures. The AIRSTREAM is optionally equipped with a frost protection thermostat on the return pipe of the heat exchanger.

For a change-over heat exchanger, the same coil is used for both after-heating in winter and after-cooling in summer. The cooling capacity is determined at an air inlet temperature of 28 °C and available cooling water of 7/12 °C.

## Airstream Hybrid

The Mark AIRSTREAM Hybrid is our Eurovent-certified heat recovery unit, equipped with indirect adiabatic cooling and a heat pump for after-heating/cooling.

The adiabat is placed in the return of the heat recovery unit. The advantage of this, is that the absolute humidity of the supply air does not increase. When the DX-cooler is also switched on, the humidity in the room will decrease further. This will improve the performance of the adiabatic cooling on very hot days with high humidity. In winter the Airstream fully functions as a high efficiency heat recovery unit. The heat pump can be used as an after-heater. By applying this principle, ventilated cooling can be used at very low operating and maintenance costs.

## Cooling

Available cooling options are:

### Direct cooling

The air flow is cooled directly, the evaporator is located in the air flow. Advantages are: no water problem (risk of freezing, glycol concentrate, corrosion), high cooling efficiency and excellent air dehumidification.

### Indirect cooling

Water is cooled in an external chiller (not in the Airstream). The cold water is transported through a pump to the cooling coil in the heat recovery unit. As a result, the air flow will be cooled. Advantages are: the chiller is arranged separately from the unit, short length, low operating costs, good efficiency, excellent dehumidification of the air and very well controllable.

### Evaporative cooling (Soft Cool)

The cooling system is based on the evaporation of water. The heat that is required for this process is withdrawn from the outside air which flows through a water-moistened cellulose filter. The air is cooled by the evaporation of water. Benefits include high air flow, ventilation and / or cooling in a single system, low operating costs and increased productivity.

Benefits:

- High efficiency
- Very low operating costs
- Environmentally friendly system
- Increases productivity
- Plug & play configuration

## Gas-fired condensing modulating heating module

Compared with a hot water coil, this option has the advantage that there is no need to provide an additional boiler. No hot water piping from and to the unit and therefore no pipe line losses. In case of an outside version no water pipe insulation is required.

The combustion of the gas takes place via the highefficiency heating module which is incorporated in the Airstream. The optional Mark G+ heating module is a high efficient condensing heating module. When used as an after-heating module, the device will be in part-load operation most of the time. This automatically leads to the highest efficiency.

### Condensing technology for decentralised heating

The burner efficiency of the Mark condensing air heater G+ reached with its modulating premix burner an efficiency of above 106% on the basis of the calorific value, so that considerable energy savings can be realised.

### The difference between the lower and upper value

The efficiency of the Mark G+ depends on the burner load. The chart on the right shows when the heating module starts to condensate when the highest

efficiency is achieved.

### Calorific value

The calorific value is the amount of energy (kJ or MJ) released at complete combustion of a unit volume of natural gas of a constant pressure (1013 mbar) and a constant temperature (20 °C).

### Calorific upper value

If the water vapor condenses completely during the combustion process, 31.50 MJ/m<sup>3</sup> of energy will be obtained (value for natural gas G25); this combustion heat is called calorific value (higher value).

### Latent heat

Upon complete combustion of 1 m<sup>3</sup> natural gas, 1.4 kg of water with a latent heat content of 3.25 MJ is formed.

### Calorific lower value

The calorific upper value minus the latent heat is called the calorific lower value or heating value. For natural gas (G25) this value is from 32.50 to 3.25 = 29.25 MJ/m<sup>3</sup>.

	Calorific upper value $H_s^*$ (kWh/m <sup>3</sup> (st))	Calorific lower value $H_l^*$ (kWh/m <sup>3</sup> (st))	$H_s / H_l$	$H_s - H_l$ kWh/m <sup>3</sup> (st)	Max. condensate quantity kg/m <sup>3</sup>
Natural gas L (G25)	9,03	8,13	1,11	0,9	1,48
Natural gas E (G20)	10,49	9,45	1,11	1,04	1,61
Propane (G31)	26,57	24,44	1,09	2,13	3,29

\* According to EN 437



## Air intake hood

The outdoor AIRSTREAM is supplied with an aluminum (AlMg<sup>3</sup>) intake hood. This hood is constructed in such a way that it has a negligible pressure drop and is weather proof. The hood is provided with so called "bird mesh" in order to keep pests, birds and leaves outside

## Dampers

Optionally, the AIRSTREAM can be provided with air dampers with air tightness class 2 (DIN EN 1751). Higher classes are available on demand.

The dampers are made of counter-rotating profiled aluminum blades with rubber sealing lips. The blades are mounted in a frame with external plastic gears.

On the operating side of the AIRSTREAM the dampers and actuators can be easily reached and inspected via the inspection door.

## Spigots

Optionally, the AIRSTREAM can be provided with vibration-free spigots for connection to an air duct.

## Recirculation damper

Optionally, the Mark AIRSTREAM is available with a recirculation damper to enable accelerated heating.



# Technical information

AIRSTREAM CFX		600	1400	2000	3200	4000	5400	6400	8600	10000	12500	15200	20000
Maximum air volume	m <sup>3</sup> /h	600	1400	2000	3200	3700	5400	6400	8600	9200	12100	14250	19400
Maximum external pressure	Pa	250	425	150	1140	915	595	375	395	720	470	450	570
Efficiency	%	90	90	90	90	90	90	90	90	90	90	90	90
Maximum current consumption per unit	A	3,6	4,7	4,7	7,9	7,9	7,9	7,7	11,4	16,7	15,6	22,5	33,2
Weight of unit for L = A1	kg	435	520	530	690	745	980	1105	1550	1505	1810	2120	2690
Weight of unit for L = A2	kg	470	565	570	745	805	1030	1180	1645	1600	1930	2245	2855
Weight of unit for L = A3	kg	510	620	620	815	870	1125	1270	1770	1725	2085	2400	3075
Weight of unit for L = A4	kg	450	540	545	715	775	995	1145	1600	1555	1870	2195	2775
Weight of unit for L = A5	kg	485	585	590	765	835	1065	1220	1700	1650	1990	2320	2940
Weight of unit for L = A6	kg	585	640	645	830	915	1145	1310	1825	1775	2145	2470	3160
Supply voltage (50Hz)	V	1~230	1~230	1~230	3~400+N	3~400+N	3~400+N	3~400+N	3~400+N	3~400+N	3~400+N	3~400+N	3~400+N

AIRSTREAM HWX		1500	3000	4500	6000	9500	12000	15000	20000	27500
Maximum air volume	m <sup>3</sup> /h	1500	3000	4500	6000	9500	12000	15000	20000	27000
Maximum external pressure	Pa	500	1250	975	580	875	500	230	845	265
Temperature efficiency	%	82,4	83,7	81,8	81	82,3	80,2	83,1	81	78,4
Humidity efficiency	%	88,8	90,9	87,7	86,4	88,6	85,3	90	86,3	81,9
Maximum current consumption per unit	A	5,0	8,5	8,5	17,2	17,5	17	16,9	34,4	29,1
Weight of unit for L = A1	kg	525	590	755	860	1115	1475	1785	1845	2245
Weight of unit for L = A2	kg	570	640	815	925	1195	1585	1895	1980	2385
Weight of unit for L = A3	kg	630	705	900	1015	1310	1745	2075	2165	2625
Weight of unit for L = A4	kg	550	625	795	900	1170	1540	1865	1935	2335
Weight of unit for L = A5	kg	600	670	855	965	1250	1655	1985	2070	2475
Weight of unit for L = A6	kg	655	735	935	1065	1365	1810	2160	2250	2715
Weight of unit for L = A7	kg	595	665	850	960	1240	1635	1965	2035	2445
Weight of unit for L = A8	kg	640	715	950	1030	1315	1750	2080	2315	2595
Weight of unit for L = A9	kg	695	785	990	1120	1430	1905	2250	2345	2825
Supply voltage (50Hz)	V	1~230	3~400+N	3~400+N	3~400+N	3~400+N	3~400+N	3~400+N	3~400+N	3~400+N

# Dimensions

Airstream CFX\*

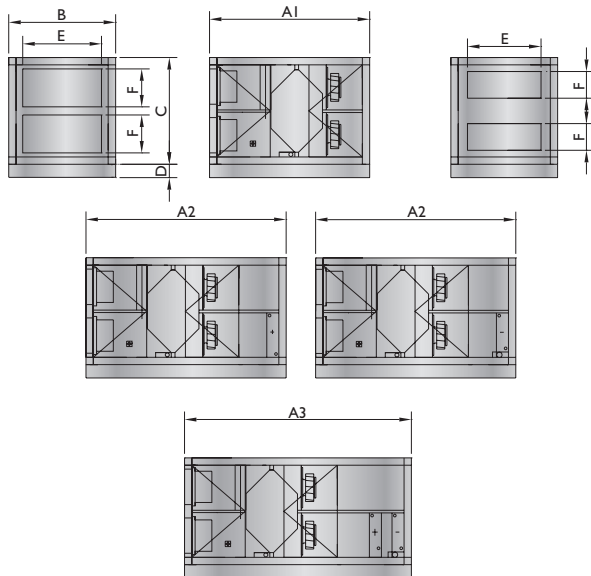

Airstream CFX with external air damper and return damper\*

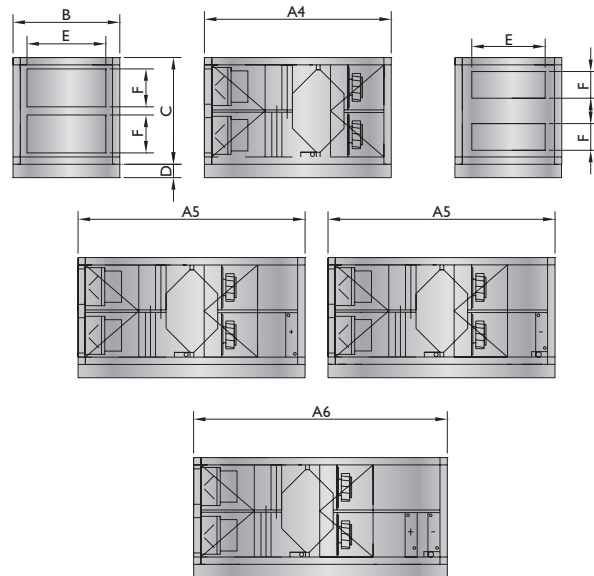

T	A1	A2	A3	A4	A5	A6	B	C	D	E	F
600	1700	2000	2200	1900	2200	2400	1000	900	100	565	265
1400	1800	2100	2300	2000	2300	2500	1100	1150	100	565	265
2000	2000	2300	2500	2200	2500	2700	1050	1150	100	565	265
3200	2100	2400	2600	2300	2600	2800	1300	1400	100	565	465
4000	2200	2500	2700	2400	2700	2900	1400	1400	100	865	465
5400	2500	2800	3000	2700	3000	3200	1500	1700	100	1155	465
6400	2600	2900	3100	2800	3100	3300	1700	1750	200	1155	565
8600	2700	3000	3200	2900	3200	3400	2400	1750	200	1455	565
10000	3000	3300	3500	3200	3500	3700	2050	1950	200	1455	565
12500	3100	3400	3600	3300	3600	3800	2500	2000	200	2030	565
15200	3600	3900	4100	3800	4100	4300	2300	2700	200	1755	865
20000	3700	4000	4200	3900	4200	4400	2950	2700	300	2030	865

- A1 Airstream CFX
- A2 Airstream CFX with post-heating or cooling coil
- A3 Airstream CFX with post-heating and cooling coil
- A4 Airstream CFX with external air damper
- A5 Airstream CFX with external air damper, post-heating or cooling coil
- A6 Airstream CFX with external air damper, post-heating and cooling coil

\* Optional change of airflow

**Airstream HWX\***

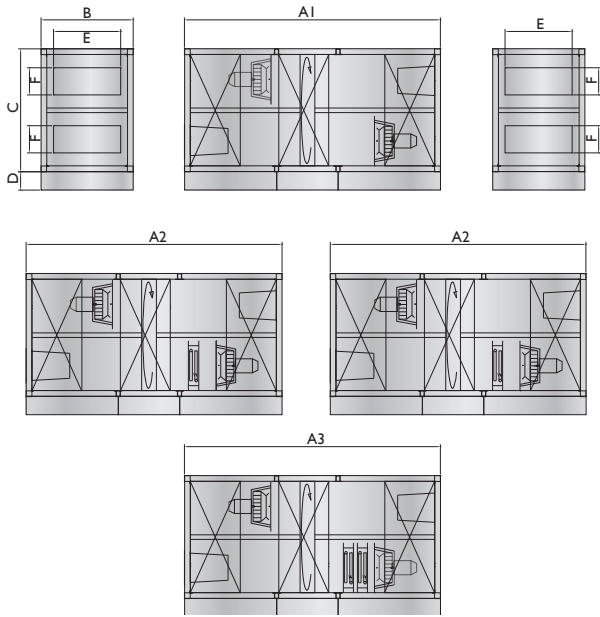

**Airstream HWX with external air damper\***

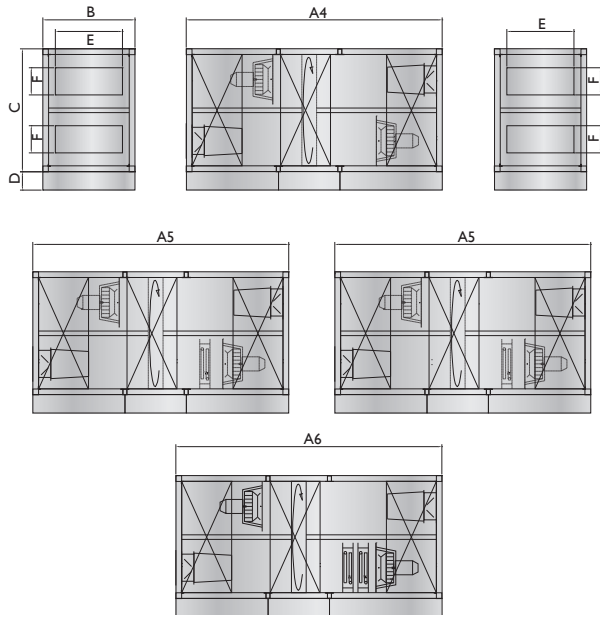

**Airstream HWX with external air damper and recirculation damper\***

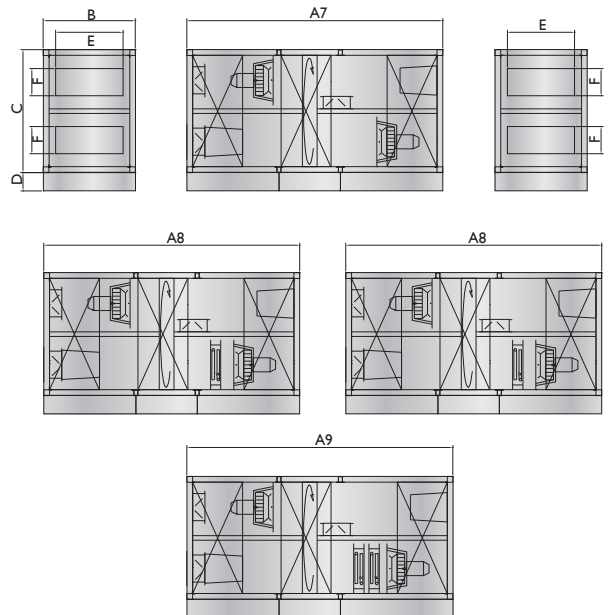

- A1 Airstream HWX
- A2 Airstream HWX with post-heating or cooling coil
- A3 Airstream HWX with post-heating and cooling coil
- A4 Airstream HWX with external air damper
- A5 Airstream HWX with external air damper, post-heating or cooling coil
- A6 Airstream HWX with external air damper, post-heating and cooling coil
- A7 Airstream HWX with external air damper and recirculation damper
- A8 Airstream HWX with external air damper, recirculation damper, post-heating or cooling coil
- A9 Airstream HWX with external air damper, recirculation damper, post-heating and cooling coil

T	A1	A2	A3	A4	A5	A6	A7	A8	A9	B	C	D	E	F
1500	1400	1650	1900	1700	1950	2200	2200	2450	2700	1200	1200	100	565	265
3000	1900	2150	2400	2200	2450	2700	2700	2950	3200	1200	1300	100	865	465
4500	1900	2150	2400	2200	2450	2700	2700	2950	3200	1500	1500	100	1155	465
6000	2100	2350	2600	2400	2650	2900	2900	3150	3400	1600	1600	100	1155	565
9500	2600	2850	3100	2900	3150	3400	3400	3650	3900	1800	1900	200	1455	565
12000	2700	2950	3200	3000	3250	3500	3500	3750	4000	2400	2000	200	2030	565
15000	2300	2550	2800	2600	2850	3100	3100	3350	3600	2400	2400	200	2030	865
20000	2600	2850	3100	2900	3150	3400	3400	3650	3900	2500	2500	200	2030	865
27500	3100	3350	3600	3400	3650	3900	3900	4150	4400	2900	2900	300	2030	865

\* Optional change of airflow



# Controls

Mark AIRSTREAM is provided with OJ-controls. This control system manages the entire unit. Frost protection for the counterflow heat exchanger, control of the bypass but also the control of the fans are included. This control system is extremely easy to adjust using the remote control or laptop / computer. For operation with laptop / computer, no additional software is needed. A network connection through webbrowser Google Chrome is all you need to get access. The menu structure is clear and intuitive, with different levels of access and authority.

It is possible to control the air amount on the basis of CO<sub>2</sub>, air quality, loss of pressure or humidity. Each unit is internally fused and completely wired from the components to the isolator switch. Optional is the control of a 3-way valve for cooler, heater or battery change-over with the release of a pump. Obviously much more is possible, we will be pleased to advise you.

## Overview basic scheme with possibilities

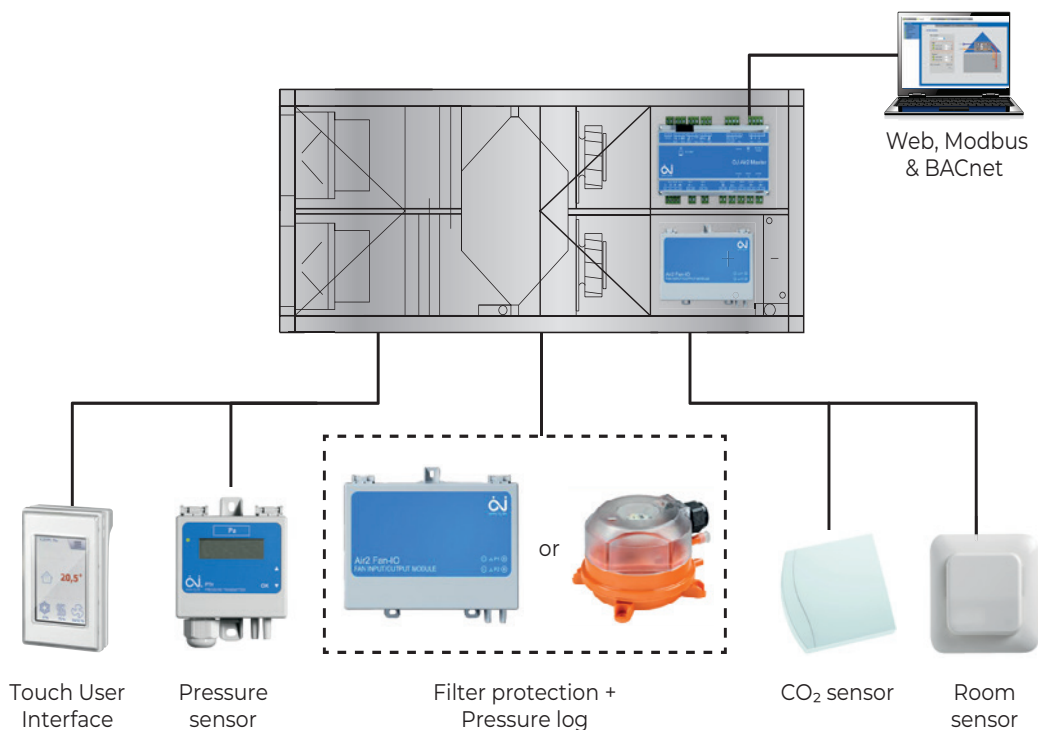

# Installation

## Positioning

The AIRSTREAM features a galvanized support frame with lifting points. In all cases, the heat recovery unit must be levelled. This is important for the evacuation of condensation water. Depending on the foundations it is advisable to install vibration mats under the base frame. This is to prevent contact noise. On the operating side a clearance of at least 600 mm must be available. This is required for maintenance on the machine and replacing the filters.

## Lifting possibilities



Lifting option 1: applies to AIRSTREAM heat recovery units to around 1000kg



Lifting option 2: applies to AIRSTREAM heat recovery units of 1000kg and more.

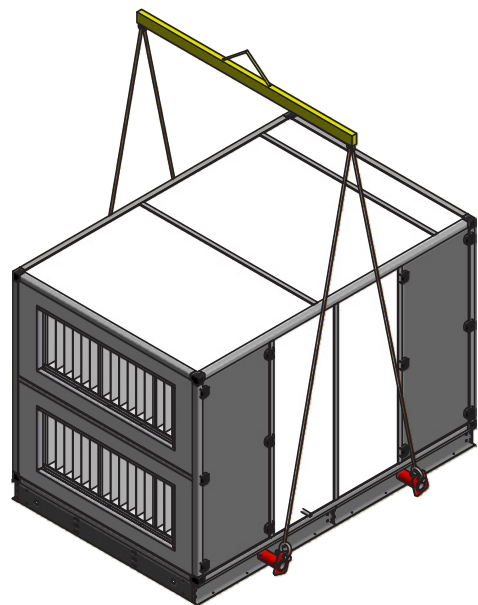

## Duct connections

In an indoor installation, the air ducts of the AIRSTREAM must be insulated to prevent condensation on the outside of the duct. In outdoor installation, the outer ducts have to be insulated in order to maintain the efficiency of the unit. It is recommended to install a silencer in the supply and extract air duct. This will prevent any noise from the fan. Besides that, noise transfer (cross-talk) from one room to the other caused by the connecting duct work must be prevented. For this, a crosstalk attenuator has to be applied.

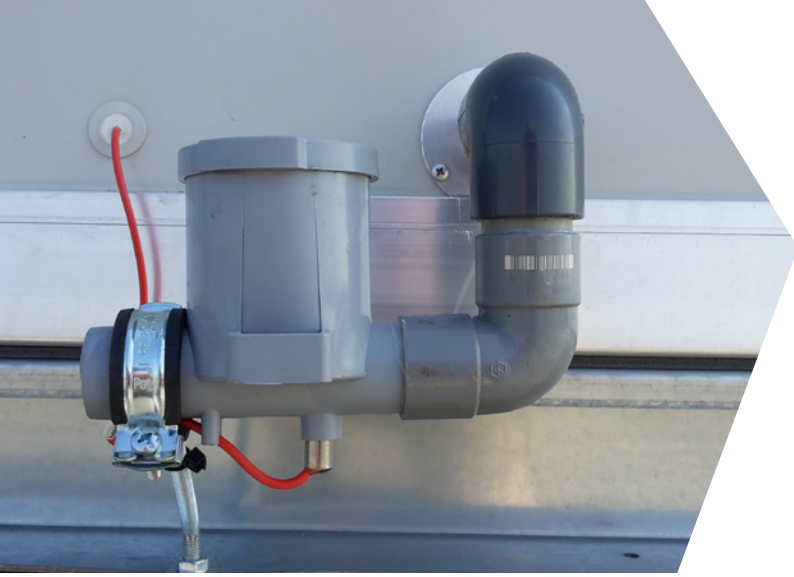

## Condensation drain

In the section where the drip tray is placed there is a maximum under pressure of 650 Pa. In order to drain the condensation water well, it is necessary to place a ball siphon. This siphon is positioned on the outside of the air handling unit and connected to the condensation drainage (min. 40 mm). This condensate can be drained through a drainpipe. In an outdoor installation the condensate water can be drained through the siphon on the roof or other sewerage. The heat recovery unit produces the most condensation water in the cold months. For outdoor installations, a heated siphon is available. This siphon ensures that condensation water can be drained properly during frost periods. The ball siphon also stops unwanted odors, that come from the sewerage system.

## Frost protection

To prevent freezing of the aluminum heat exchanger there is a security in the electric controls. This works fully automatically and is pre-programmed in the factory.

## Assembly on site

The AIRSTREAM might be too large to place inside certain areas. In such cases there is the possibility of assembling on location. After the unit has been produced and tested in our factory, it will be dismantled and transported in parts to the location. Our service engineers will re-assemble the heat recovery unit on site.

## Electrical connections

The AIRSTREAM is completely wired internally. The isolator switch and cable box are wired and mounted on the outside of the heat recovery unit. The isolator switch is connected with the power supply.

The electric power supply of this air handling unit is either 230V or 400V. This depends on the size of the unit. This information can be found on the type plate on the inside of the inspection door. The information on the type plate also shows the fuse value to select the right fuse in the building.

On the cable box a remote control and cabling for BMS, start / stop, fire and any other external controllers can be connected. The schedule for the above connections can be found in the control compartment of the heat recovery unit.

The heat recovery unit is prepared for a fire signal. If the unit receives a fire signal, it is turned off. Once the unit is turned off, the heat recovery unit must be restarted using the control panel.



# Certificates

## Eurovent certificate

## RLT Richtlinie-01 certificate



**CERTIFICATE**  
N° 17.07.011



Air Handling Unit / Centrales de traitement d'air

Range Name / Nom de Gamme :  
**AIRSTREAM**

Granted on July 26, 2017 - Date 1ère admission 26 juillet 2017

This document is valid at the date of issue - Check the current validity on:  
Document valable à la date d'émission - Vérifier la validité en cours sur :  
[www.eurovent-certification.com](http://www.eurovent-certification.com)

Participant/Titulaire

**MARK CLIMATE TECHNOLOGY**  
Beneden Vortaat 97-99  
NL-9645BM Veendam, The Netherlands

This product performance certificate is issued by Eurovent Certita Certification according to the certification rules:

ECP AHU - « Air Handling Unit » in force at established date.

Pursuant to the decision notified by Eurovent Certita Certification, the right to use the mark ECP shall be granted to the beneficiary company for the above Range in the conditions defined by the certification program mentioned.

Unless withdrawn or suspended, this certificate remains valid as long as the requirements for the certification program framework are met. The validity of the certificate is to be verified on [www.eurovent-certification.com](http://www.eurovent-certification.com)

THIS CERTIFICATE HAS BEEN ISSUED ON 24/06/2025  
THIS CERTIFICATE IS VALID UNTIL 31/12/2025

Ce certificat de performance produit est délivré par Eurovent Certita Certification dans les conditions fixées par le référentiel :

ECP AHU - « Centrales de traitement d'air » en vigueur à date d'édition.

En vertu de la décision notifiée par Eurovent Certita Certification, le droit d'usage de la marque ECP, est accordé à la société qui en est bénéficiaire pour la gamme visée ci-dessus, dans les conditions définies par le programme de certification mentionné.

Sauf retrait ou suspension, ce certificat demeure valide tant que les conditions du référentiel du programme de certification sont respectées. La validité du certificat est à vérifier sur le site internet [www.eurovent-certification.com](http://www.eurovent-certification.com)

CE CERTIFICAT A ÉTÉ EMIS LE 24/06/2025  
CE CERTIFICAT EST VALIDE JUSQU'AU 31/12/2025

Paris, 24 juin 2025



Organisme accrédité n° 5-0517 Certification Produits et Services selon le norme NF-EN ISO/CEI 17065:2012  
Portée disponible sur [www.cofrac.fr](http://www.cofrac.fr)  
Accréditation ISO/CEI 17065 Produits et Services Certification according to NF-EN ISO/CEI 17065:2012 - Scope available on [www.cofrac.fr](http://www.cofrac.fr)  
COFRAC est signataire des accords MIA d'EA.  
COFRAC is signatory of EA MIA.  
Its EA members is available on [www.eurovent-certification.com](http://www.eurovent-certification.com)

MANAGING BOARD MEMBER / MEMBRE DIRECTOIRE

EUROVENT CERTITA CERTIFICATION SAS au capital de 70 000 € - 34 rue Laffitte 75009 Paris - FRANCE  
Tel. : 33 (0)1 75 44 71 71 - 513 133 637 RCS Paris - TVA FR 59513133637

1/2

CERTIFICATE TEMPLATE\_ECP\_RANGE\_REV2.0

CERTIFICAT

CERTIFICADO

證明書

СЕРТИФИКАТ

CERTIFICATE

ZERTIFIKAT



Hiermit wird der Firma

**Mark B.V.**  
in  
**NL-9640 AA Veendam**

aufgrund der mit positivem Ergebnis abgeschlossenen  
Überprüfung der

**RLT-Geräte-Auslegungs-Software**  
**„MARKAHU BV Select“**  
**Version 1.4.x**

bestätigt, dass die Anforderungen gemäß dem Prüf- und Zertifizierungsprogramm  
„RLT-RICHTLINIE Zertifizierung“: 2017-11 erfüllt wurden.

Der Hersteller ist berechtigt folgende Prüfzeichen zu benutzen:



Das Zertifikat ist gültig bis einschließlich 30.06.2026

Zertifikat-Registrier-Nr.: 15/10/22



*Signature*  
Zertifizierungsstelle für Produkte  
Kälte- und Klimatechnik  
München, 27.05.2024



Dieses Zertifikat gilt nur in Verbindung mit der folgenden Anlage, bestehend aus einer Seite

TÜV SÜD INDUSTRIE SERVICE GMBH, WESTENDSTRASSE 199, D-80686 MÜNCHEN  
certification-TAK@tuv-sud.com

TUV®







**mark**

building climate technology

**Mark Climate Technology**

Beneden Verlaat 87-89  
9645 BM Veendam  
Nederland

+31 (0)598 656612  
info@markclimate.com  
www.markclimate.com

**in** [www.linkedin.com/company/  
mark-climate-technology](http://www.linkedin.com/company/mark-climate-technology)

